



QNAP

QGD-1600P

使用者指南

目錄

1. 前言

關於本指南.....	3
適用對象.....	3
慣用符號.....	3

2. 產品概觀

關於 QGD-1600P.....	4
硬體規格.....	4
包裝內容.....	6
元件.....	6
前方面板.....	7
前方面板 LED 燈.....	8
背部面板.....	9
系統板.....	9
安全資訊.....	10
安裝需求.....	10
設定交換器.....	11

3. 安裝與設定

硬體安裝.....	12
取下機殼蓋.....	12
裝上機殼蓋.....	13
在 2.5 吋托盤上安裝 2.5 吋硬碟或固態硬碟.....	14
更換記憶體模組.....	17
安裝擴充卡.....	20
安裝橡膠腳座至交換器.....	24
安裝交換器支架.....	26
連接交換器至電腦或網路.....	27
連接 USB 擴充設備.....	29
QTS 安裝.....	30
使用 Qfinder Pro 安裝 QTS.....	30
使用 Cloud Key 安裝 QTS.....	31
使用 HDMI 連線安裝 QTS.....	33
交換器管理應用程式存取.....	33
在 QTS 存取 QuNetSwitch.....	34
透過 Qfinder Pro 存取 QSS.....	34

4. 基本操作

按鈕.....	36
主機電源按鈕.....	36
交換器重設按鈕.....	36
QTS 重設按鈕.....	36
LCD 面板.....	37
檢視 TCP/IP 設定.....	37
配置 TCP/IP 設定.....	37
檢視硬碟資訊.....	38
檢視系統資訊.....	38
關閉交換器電源.....	38
重新啟動交換器.....	39
變更 LCD 密碼.....	39
LCD 錯誤訊息.....	39

LED 燈號.....	40
警示音.....	41
5. 疑難排解	
熱插拔故障硬碟.....	42
強制 Qfinder Pro 以及 myQNAPcloud 定位交換器.....	42
支援和其他資源.....	42
6. 詞彙	
myQNAPcloud.....	44
myQNAPcloud Link.....	44
Qfinder Pro.....	44
QuNetSwitch.....	44
QTS.....	44
QSS.....	44
7. 聲明	
有限保固.....	45
免責聲明.....	45
GNU Public License.....	45
CE 聲明.....	53
FCC 聲明.....	53
VCCI 聲明.....	53
經濟部標準檢驗局聲明.....	54
SJ/T 11364-2006.....	54

1. 前言





關於本指南

本指南涵蓋 QNAP QGD-1600P 網路交換器的相關資訊，以及安裝硬體的逐步指示。此外，本指南也提供基本操作說明與疑難排解資訊。

適用對象

本文件的適用對象為消費者與網路管理員。本指南預設使用者具有網路、儲存與備份的基本概念。

慣用符號

符號	說明
	注意事項。用於提供預設組態設定與其他補充資訊。
	重要注意事項。用於提供必要組態設定及其他重要資訊。
	提示。用於提供任務執行或組態設定的建議或替代方式。
	警告。忽略此類資訊可能導致潛在損失、受傷甚至死亡事故。

2. 產品概觀

本章介紹 QNAP QGD-1600P 交換器的基本資訊。

關於 QGD-1600P

QGD-1600P 是 QNAP 的第一台智慧邊緣網路交換器，具有內建儲存容量。這款交換器以軟體定義網路 (SDN)，並支援多種 SMB 應用，包含 NAS、NVR、路由器、防火牆、AP 控制器及監控。QGD-1600P 支援虛擬機器 (VM) 且具備 4 個 60 瓦連接埠及 12 個 30 瓦連接埠 Gigabit 乙太網路供電 (PoE)。這款交換器的雙 CPU 設計為 VM 和 QTS 應用提供 Layer 2 管理功能。

硬體規格



警告

如果您的 QNAP 產品有硬體瑕疵，請將產品寄回 QNAP 或 QNAP 授權服務中心進行維修或換貨。只要您或未經授權的第三方嘗試修復產品或執行產品維修流程，皆會導致產品保固失效。

對於因未獲授權進行修改或安裝不支援之第三方應用程式所導致的任何損害或資料遺失，QNAP 一概不予負責。

如需詳細資訊，請參見：[QNAP 保固條款與條件](#)。



提示

型號規格如有變更，恕不另行通知。若要查看最新規格，請前往 <https://www.qnap.com>。

訂購料號	處理器	記憶體	電源供應器
QGD-1600P-4G	Intel® Celeron® J4115	4 GB	單一
QGD-1600P-8G	Intel® Celeron® J4115	8 GB	單一

元件	QGD-1600P-4G	QGD-1600P-8G
處理器	Intel® Celeron® J4115	
頻率	4 核心/4 執行緒 1.8 GHz 基頻/2.5 GHz 超頻	
架構	x86 64 位元	
加密引擎	AES-NI	
繪圖技術	Intel® HD Graphics 600	
記憶體		
預載記憶體	4 GB RAM : 1 x 4 GB SODIMM DDR4	8 GB RAM : 2 x 4 GB SODIMM DDR4
記憶體插槽	2 x 4 GB SODIMM DDR4	
	重要 僅限使用 QNAP 記憶體模組以維護系統效能和穩定性。若是具有一個以上記憶體插槽的硬碟，請使用規格相同的 QNAP 記憶體模組。 使用不支援的記憶體模組會導致效能降級、產生錯誤，或造成作業系統無法啟動。	
最大記憶體	8 GB RAM : 2 x 4 GB	
快閃記憶體	4 GB (雙啟動作業系統防護)	
儲存		

元件	QGD-1600P-4G	QGD-1600P-8G
硬碟插槽	2 x 2.5 吋 SATA 6 Gbps  注意 該介面與 SAS 3 Gbps 硬碟回溯相容。	
硬碟相容性	<ul style="list-style-type: none"> • 2.5 吋 SATA 硬碟 • 2.5 吋 SATA 固態硬碟 	
SSD 快取加速技術支援	2.5 吋硬碟插槽：1 與 2	
熱抽換	支援	
連接埠		
Gigabit 乙太網路埠	<ul style="list-style-type: none"> • 2 x 1 GbE SFP/RJ45 複合式連接埠 • 14 x 1 GbE RJ45 	
PoE 支援		
802.3af (PoE)	連接埠 1 至 16  注意 這些連接埠支援 IEEE 802.3af-2003 PoE 標準並可提供達 15.4W 電源。	
802.3at (PoE+)	連接埠 1 至 16  注意 這些連接埠支援 IEEE 802.3at-2009 PoE 標準並可提供達 30W DC 電源。	
802.3bt (PoE++)	連接埠 1 至 4  注意 這些連接埠支援 IEEE 802.3bt-2018 PoE 標準並可提供達 60W DC 電源。	
PoE 最高電源埠	<ul style="list-style-type: none"> • 連接埠 1 至 4：最高 60W • 連接埠 5 至 16：最高 30W 	
PoE 功率總預算	370W  警告 為了降低走火或觸電風險，務必只將電源線連接至適當的接地電源插座。	
總耗電量	418W	
外接 I/O 埠和擴充插槽		
PCIe 插槽	2 x PCIe 2.0 x2  提示 請前往 https://www.qnap.com/compatibility 查看相容的擴充卡清單。	
USB 連接埠	<ul style="list-style-type: none"> • 1 x USB 3.0 Type-A • 2 x USB 2.0 Type-A 	
HDMI 連接埠	1 x HDMI 2.0 (HDR 影像可高達 3840 x 2160、30Hz 解析度)	
介面		

元件	QGD-1600P-4G	QGD-1600P-8G
顯示面板	單色背光 LCD 顯示面板	
按鈕	<ul style="list-style-type: none"> • Enter (進入) • Select (選擇) • QTS 重設 • 交換器重設 • 系統電源 	
交換器	電源設定	
尺寸		
外型	1U 機架式	
尺寸 (高 x 寬 x 深)	160 × 528 × 403 mm (62.99 × 207.87 × 158.66 in)	
淨重	4.41 kg (9.72 lbs)	
其他		
滑軌相容性	<ul style="list-style-type: none"> • RAIL-B02 • SP-EAR-BLK-01 <p> 注意 RAIL-B02 機架滑軌和 SP-EAR-BLK-01 機架耳需另外購買。如需詳細資訊，請參見：QNAP 配件商店。</p>	
系統電池	CR2032 鋰電池 (3V · 225 mAh)	
風扇	系統：2 x 12V DC 風扇 (40 mm)	
工作溫度	0°C 到 45°C (32°F 到 113°F)	
相對濕度	<ul style="list-style-type: none"> • 不凝結相對溼度：5% 至 95% • 濕球溫度：27°C (80.6°F) 	

包裝內容

項目	數量
QGD-1600P	1
電源線	1
乙太網路線	1 x 1GbE (Cat5e)
2.5 吋硬碟用螺絲	6
滑軌支架螺絲	4
滑軌支架	2
橡膠腳座	4
快速安裝手冊 (QIG)	1

元件

前方面板

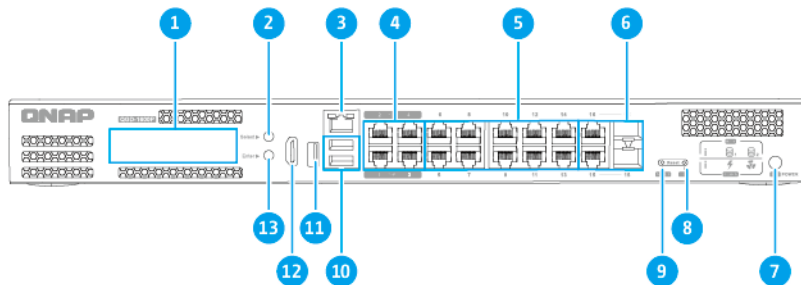

編號	元件	編號	元件
1	LCD 面板	8	QTS 重設按鈕
2	Select (選擇) 按鈕	9	交換器重設按鈕
3	主機連接埠	10	USB 2.0 A 型連接埠
4	Gigabit 802.3at PoE++ 連接埠	11	USB 3.0 A 型連接埠
5	Gigabit 802.3at PoE+ 連接埠	12	HDMI 2.0 連接埠
6	Gigabit 802.3at PoE+/SFP 複合式連接埠	13	Enter (進入) 按鈕
7	主機電源按鈕	-	-

前方面板 LED 燈

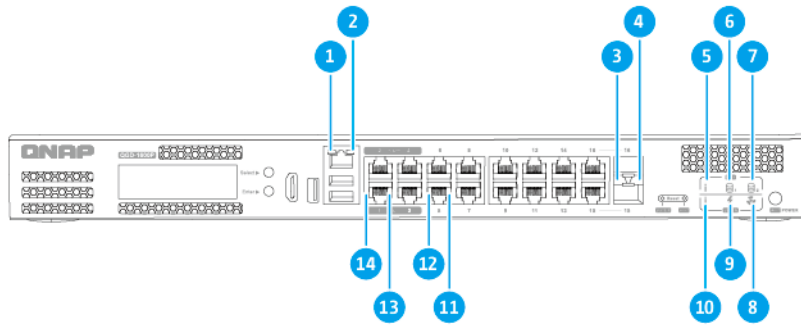

編號	元件	編號	元件
1	主機連接埠速度 LED 燈	8	風扇 LED 燈
2	主機連接埠活動 LED 燈	9	電源 LED 燈
3	複合式連接埠速度 LED 燈	10	交換式集線器狀態 LED 燈
4	複合式連接埠活動 LED 燈	11	Gigabit 802.3at PoE+ 連接埠速度 LED 燈
5	QTS 狀態 LED 燈	12	Gigabit 802.3at PoE+ 電源活動 LED 燈
6	硬碟 1 LED 燈	13	Gigabit 802.3bt PoE++ 連接埠活動 LED 燈
7	硬碟 2 LED 燈	14	Gigabit 802.3bt PoE++ 電源速度 LED 燈

背部面板

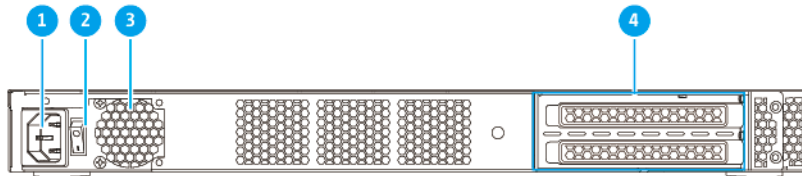

編號	元件	編號	元件
1	電源輸入	3	系統風扇
2	系統電源開關	4	PCIe 長蓋

系統板

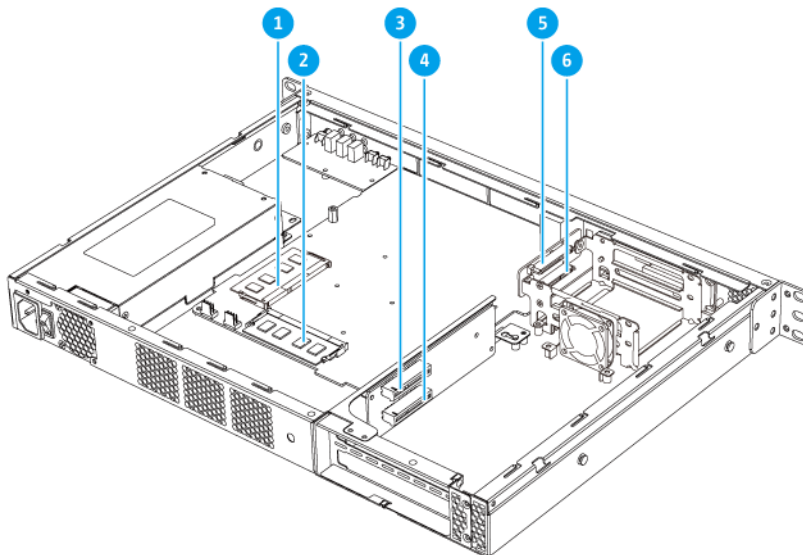

編號	元件	編號	元件
1	記憶體插槽 2	4	PCIe 2.0 x2 插槽 2
2	記憶體插槽 1	5	硬碟接頭 1
3	PCIe 2.0 x2 插槽 1	6	硬碟接頭 2

安全資訊

以下指示幫助確保人身安全及環境安全。執行任何操作前，請仔細閱讀本安全指示。

一般指示

- 裝置應放置在實施進出管制的場所，控管方式包括工具、鎖鑰或其他安全機制。
- 唯有具技能且獲得授權的合格裝置管理員能夠存取裝置；合格裝置管理員必須熟悉所有管制方法、安全注意事項、安裝及保養程序。
- 為避免受傷或元件損壞，在觸碰硬碟及其他內部系統元件前，請先確認其是否已經冷卻。
- 請遵守靜電放電 (ESD) 程序以防止潛在傷害或元件損壞。

電源

- 為了降低走火或觸電風險，務必只將電源線連接至適當的接地電源插座。



具有備援電源供應器的裝置可能配備一條或以上電源供應器 (PSU) 的電源線。為防止嚴重傷害事故發生，在安裝或更換系統元件前，所有 PSU 電源線必須由經訓練之維修技術人員從裝置拔除。

系統電池

- 更換電池時，請務必使用相同類型的電池，以免電池爆炸造成受傷或元件損壞。
- 請遵照當地法規或電池製造商的指示妥善處置廢棄電池。

移動零件



移動之風扇葉片：裝置連接至電源時，請使身體部位遠離移動中之風扇葉片。



移動元件：使身體部位遠離其他移動元件。

安裝需求

類別	項目
環境	<ul style="list-style-type: none"> • 室溫：0°C 到 45°C (32°F 到 113°F) • 不凝結相對溼度：5% 至 95% • 平坦且防靜電的表面，不受陽光直射，亦不與液體或化學物質接觸 • 確認沒有物體會阻礙裝置的通風口，或者對裝置或電源線產生壓力。

類別	項目
硬體和週邊設備	<ul style="list-style-type: none"> • 儲存硬碟 請前往 https://www.qnap.com/compatibility 以查看相容的硬碟機型清單。 • 網路線 • RAIL-B02 • SP-EAR-BLK-01
工具	<ul style="list-style-type: none"> • 1 號或 2 號十字螺絲起子 • 平頭螺絲起子 • 防靜電腕帶

設定交換器

1. 將交換器置於符合需求的環境。
如需詳細資訊，請參見：[安裝需求](#)。
2. 安裝硬碟。
如需詳細資訊，請參見：[在 2.5 吋托盤上安裝 2.5 吋硬碟或固態硬碟](#)。
請前往 <http://www.qnap.com/compatibility> 查看相容的硬碟清單
3. 選擇性: 更換記憶體模組。
如需詳細資訊，請參見：[更換記憶體模組](#)。
4. 選擇性: 安裝擴充卡。
如需詳細資訊，請參見：[安裝擴充卡](#)。
5. 將交換器安裝到機架上。
您可以在機架滑軌的包裝中找到安裝資訊。
6. 打開交換器電源。
如需詳細資訊，請參見：[背部面板](#)。
7. 連接交換器至電腦或網路。
如需詳細資料，請參見：[連接交換器至電腦或網路](#)。
8. 安裝 QTS。
如需詳細資訊，請參見：[QTS 安裝](#)。
9. 登入 QTS。
10. 管理交換器上的裝置。
如需詳細資訊，請參見：[交換器管理應用程式存取](#)。

3. 安裝與設定

本章介紹特定硬體及韌體的安裝與設定步驟。

硬體安裝

本節提供關於各種硬體安裝程序的資訊。

取下機殼蓋



警告

-



轉動中之風扇葉片：使雙手及其他身體部位遠離轉動中之風扇葉片。

-



其他移動元件：使雙手及其他身體部位遠離其他移動元件。

1. 關閉交換器電源。
2. 從電源插座拔下電源線。
3. 中斷所有連接線和外接裝置的連線。
4. 卸除上蓋。
 - a. 取下螺絲。

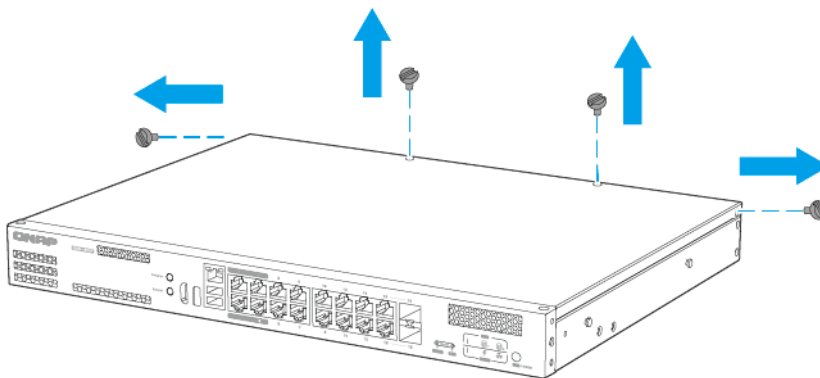

- b. 將殼蓋往後推。

- c. 拿起殼蓋。

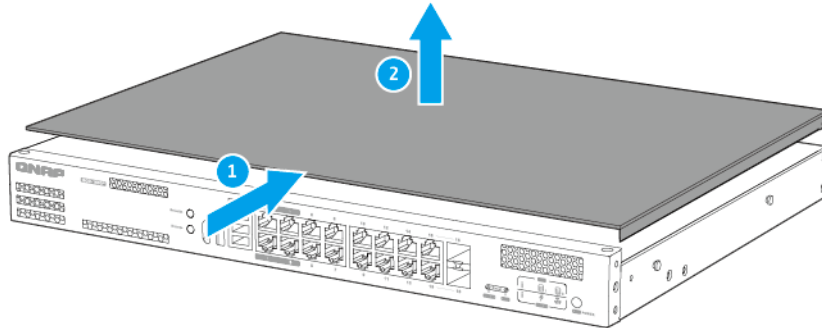

裝上機殼蓋



警告

•



轉動中之風扇葉片：使雙手及其他身體部位遠離轉動中之風扇葉片。

•



其他移動元件：使雙手及其他身體部位遠離其他移動元件。

1. 將機殼蓋裝至交換器。
 - a. 將機殼蓋置於機體上。
 - b. 將殼蓋往前推。

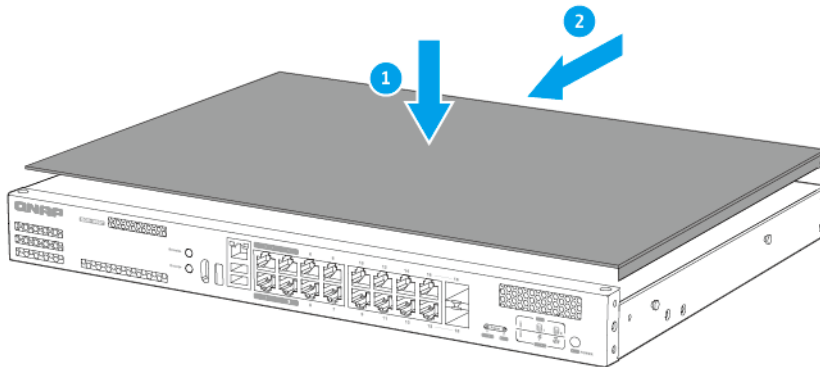

2. 鎖上螺絲。

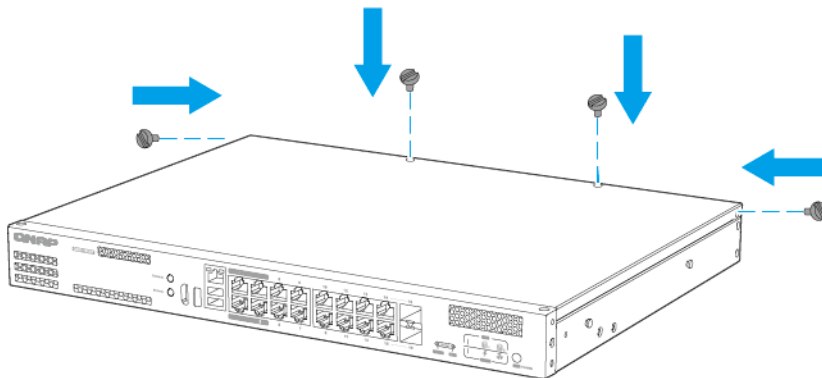

3. 連上所有連接線和外接裝置。
4. 將電源線插入電源插座。
5. 打開交換器電源。

在 2.5 吋托盤上安裝 2.5 吋硬碟或固態硬碟

QGD-1600P 與 2.5 吋硬碟以及 2.5 吋固態硬碟相容。



警告

- 安裝硬碟會刪除硬碟上的所有資料。



轉動中之風扇葉片：使雙手及其他身體部位遠離轉動中之風扇葉片。



其他移動元件：使雙手及其他身體部位遠離其他移動元件。

1. 關閉交換器電源。
2. 取下殼蓋。
如需詳細資訊，請參見：[取下機殼蓋](#)。
3. 卸除硬碟模組。
 - a. 取下螺絲。
 - b. 將硬碟模組從交換器取出。

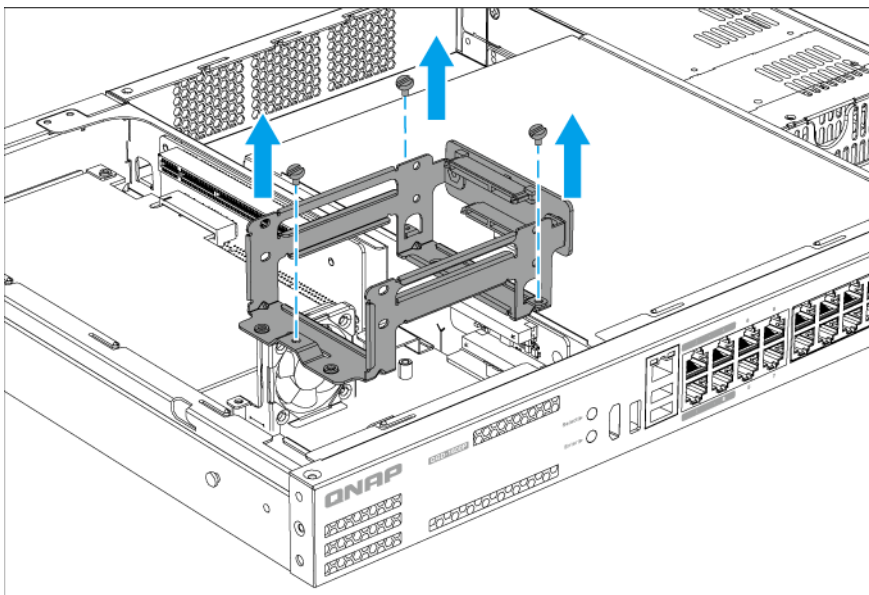

4. 將硬碟裝入硬碟模組。
 - a. 將硬碟插入插槽。

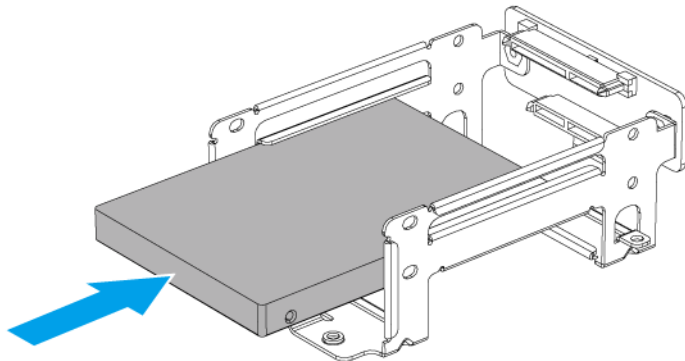

b. 鎖上螺絲。

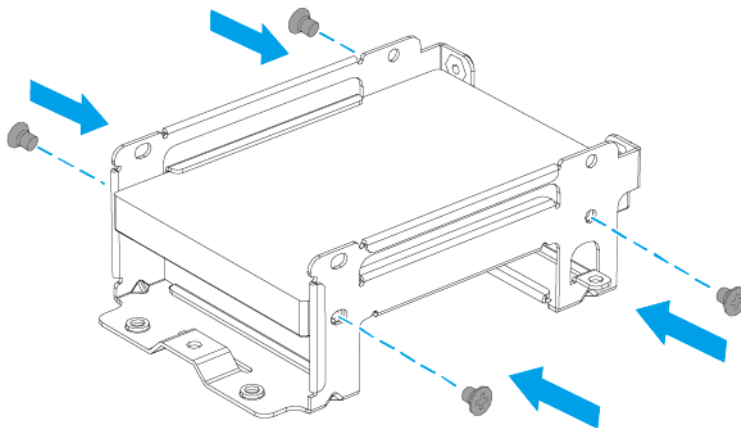

5. 插入硬碟模組。

- a. 將硬碟模組接頭對齊主機板。
- b. 將硬碟模組放入交換器並將之連接至主機板。
- c. 鎖上螺絲。

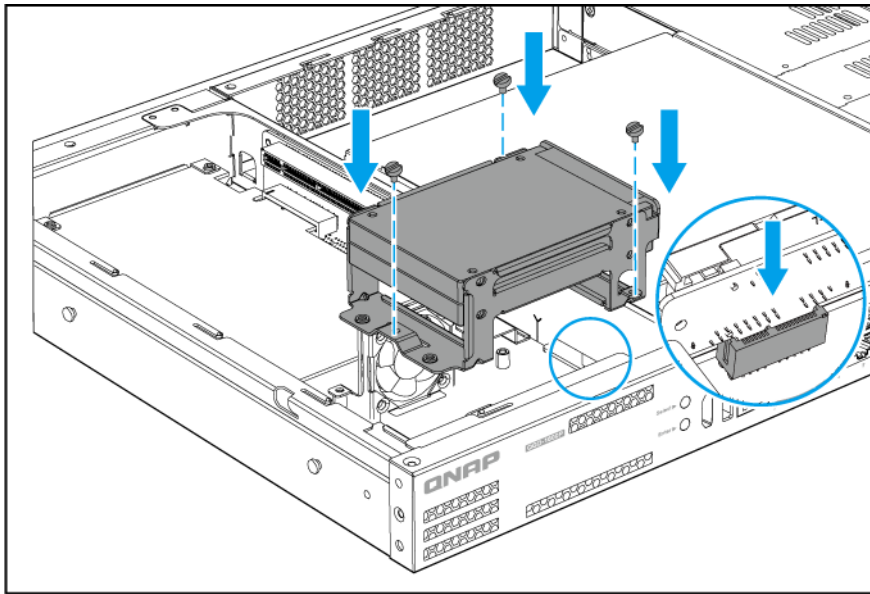

6. 裝上機殼蓋。
如需詳細資訊，請參見：[裝上機殼蓋](#)。
7. 打開交換器電源。

更換記憶體模組

QGD-1600P 具有兩個記憶體插槽。QGD-1600P-4G 會預先安裝記憶體模組，而 QGD-1600P-8G 有兩個預先安裝的記憶體模組。您可以升級記憶體模組以增加交換器的記憶體容量。使用兩個記憶體模組時，僅用相同類型與容量的 QNAP 記憶體模組，以維持系統效能和穩定性。您可向授權經銷商購買 QNAP 記憶體模組。



警告

- 請遵守靜電放電 (ESD) 程序以防止元件損壞。

-



轉動中之風扇葉片：使雙手及其他身體部位遠離轉動中之風扇葉片。

-



其他移動元件：使雙手及其他身體部位遠離其他移動元件。

1. 關閉交換器電源。
2. 從電源插座拔下電源線。
3. 中斷所有連接線和外接裝置的連線。
4. 取下機殼蓋。
如需詳細資訊，請參見：[取下機殼蓋](#)。

5. 取下現有的記憶體模組。
 - a. 將固定夾同時往外推以鬆開記憶體模組。

**警告**

若嘗試取下未完全鬆脫的記憶體模組，可能會損壞記憶體模組與主機板。

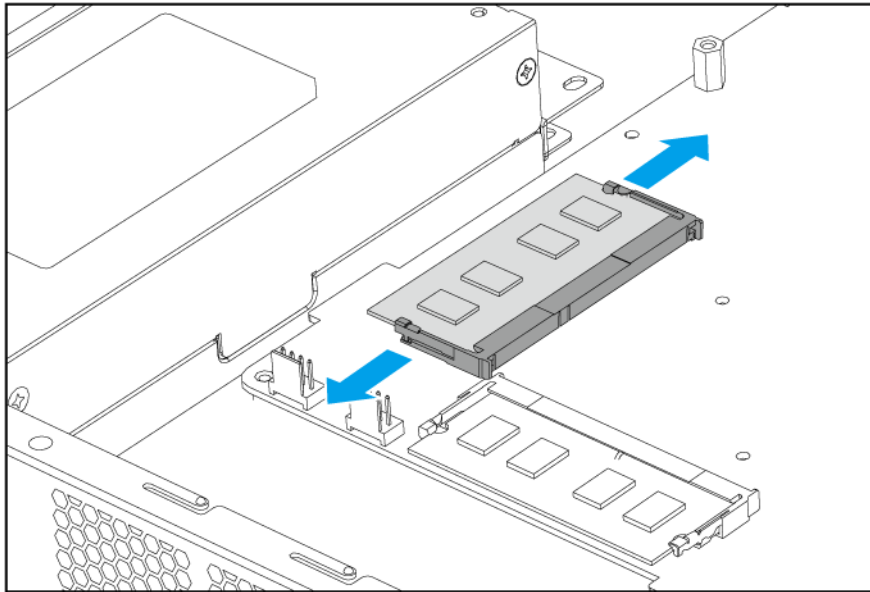

- b. 確認記憶體模組已向上傾斜且完全從插槽鬆脫。
- c. 握住模組的邊緣。
- d. 小心地將模組滑出插槽。

**警告**

若嘗試取下未完全鬆脫的記憶體模組，可能會損壞記憶體模組與主機板。

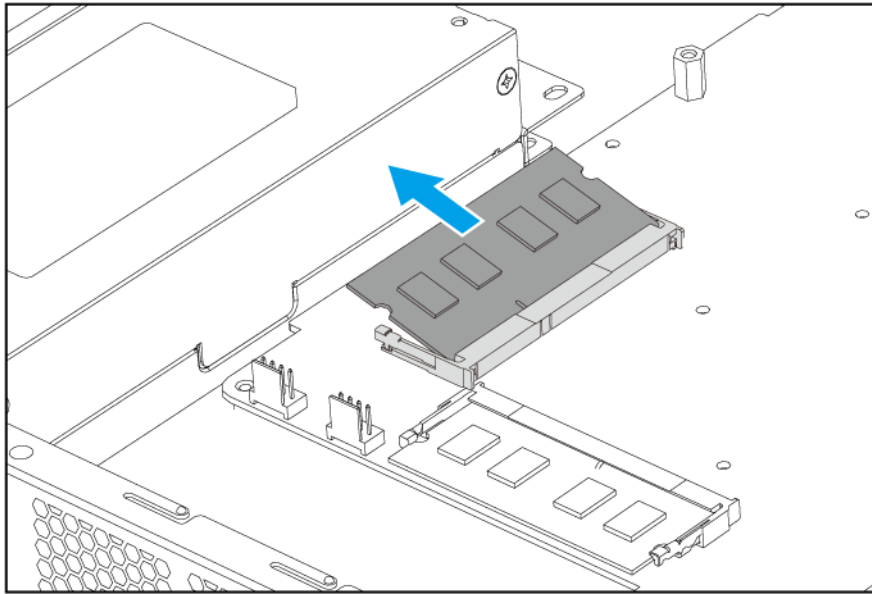

6. 安裝新的記憶體模組。
 - a. 將接口與插槽的凸出部分對齊。
 - b. 將記憶體模組插入插槽。
 - c. 確認金屬接頭已完全插入插槽。
 - d. 小心按下記憶體模組，直到固定夾正確扣住記憶體模組。

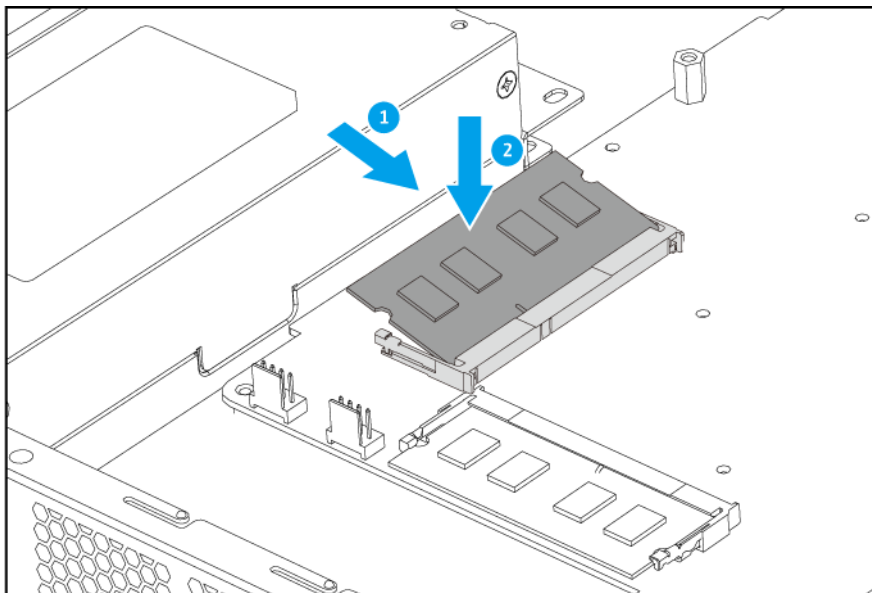

7. 裝上機殼蓋。
如需詳細資訊，請參見：[裝上機殼蓋](#)。
8. 連上所有連接線和外接裝置。
9. 將電源線插入電源插座。

10. 打開交換器電源。

安裝擴充卡

QGD-1600P 支援特定的擴充卡，其中部分需要使用 QNAP PCIe 固定片。在公司網站購買的 QNAP 擴充卡會隨附所有 QNAP 裝置適用的必要固定片。

如需支援的擴充卡與固定片詳細資訊，請前往 <http://www.qnap.com/compatibility>。



警告

- 請遵守靜電放電 (ESD) 程序以防止元件損壞。

-



轉動中之風扇葉片：使雙手及其他身體部位遠離轉動中之風扇葉片。

-



其他移動元件：使雙手及其他身體部位遠離其他移動元件。

1. 關閉交換器電源。
2. 從電源插座拔下電源線。
3. 中斷所有連接線和外接裝置的連線。
4. 取下機殼蓋。
如需詳細資訊，請參見：[取下機殼蓋](#)。



警告

為避免受傷或元件損壞，在觸碰硬碟及其他內部系統元件前，請先確認其是否已經冷卻。

5. 取下 PCIe 模組。
 - a. 取下背部面板的螺絲。

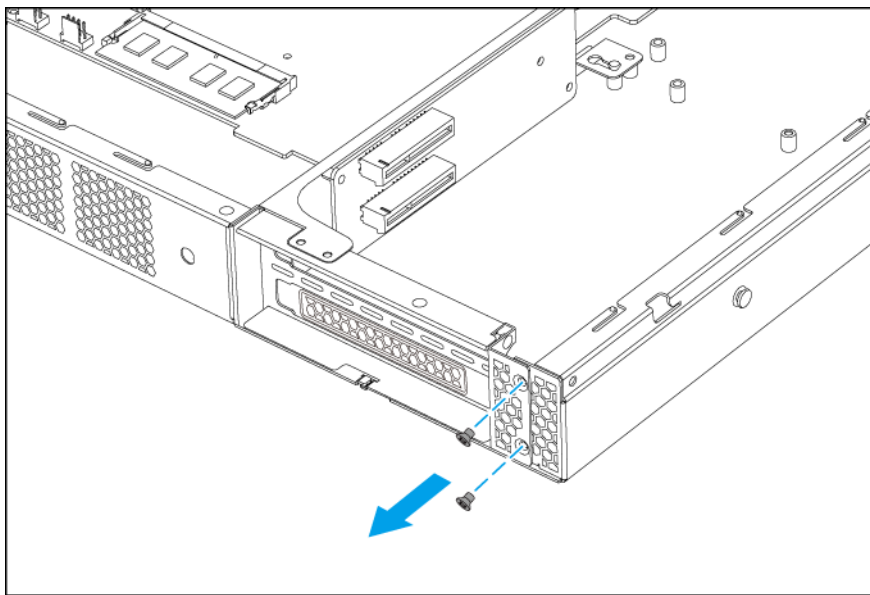

b. 卸除 PCIe 模組螺絲。

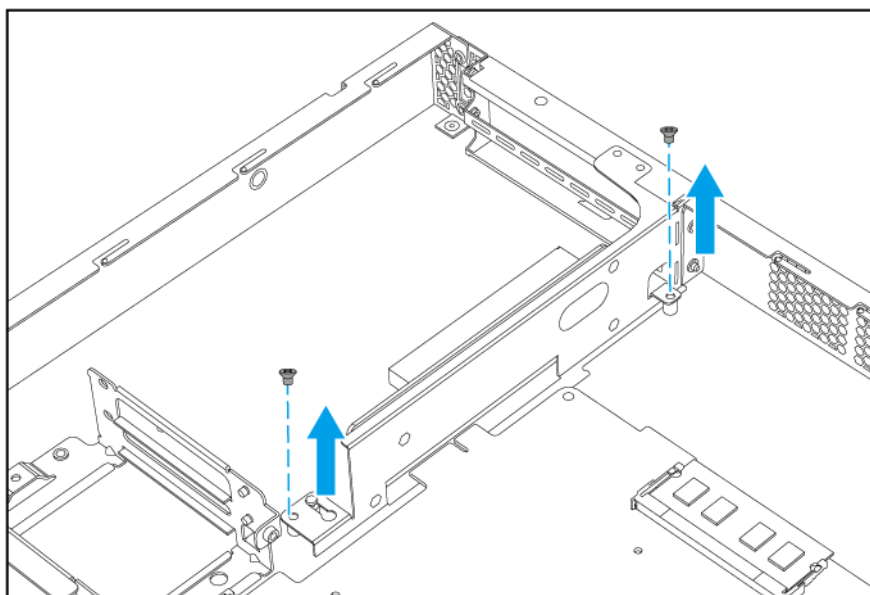

c. 將 PCIe 模組向右拉，使它完全脫離系統板。

d. 取下 PCIe 模組。

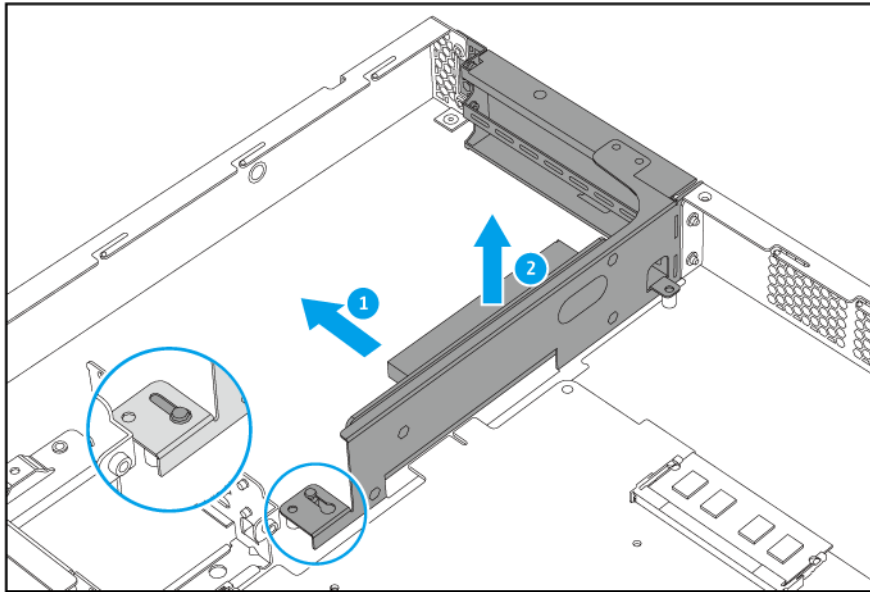

6. 取下 PCIe 插槽蓋。
 - a. 取下用於固定殼蓋和機殼的螺絲。
 - b. 將殼蓋向左推。

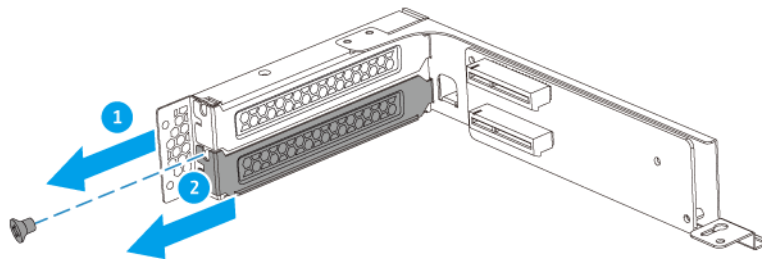

7. 安裝擴充卡。
 - a. 握住擴充卡的邊緣。
 - b. 將擴充卡插入插槽。
 - c. 鎖上螺絲。

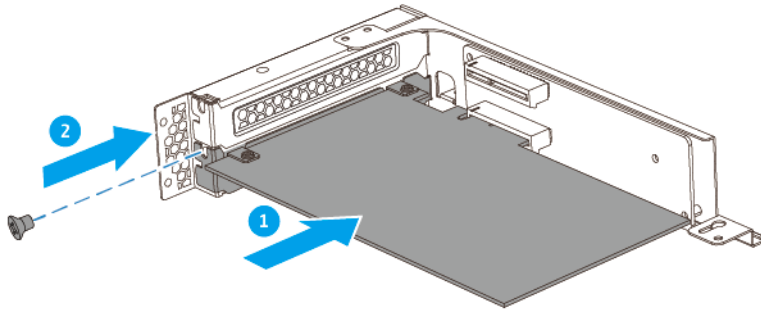

8. 安裝 PCIe 模組。

- a. 將 PCIe 模組接頭對齊系統板。
- b. 將 PCIe 模組向左拉，使它完全與系統板連接。

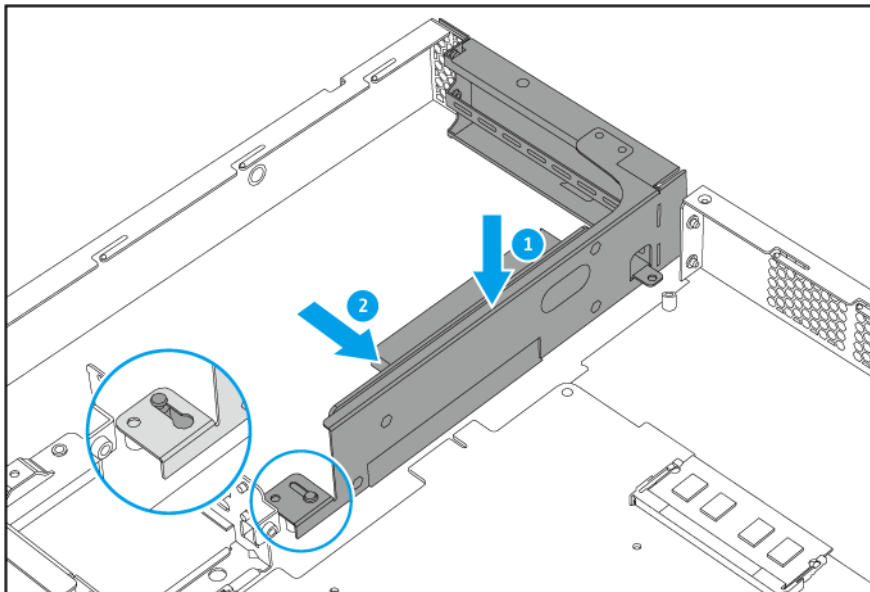

- c. 鎖上 PCIe 模組螺絲。

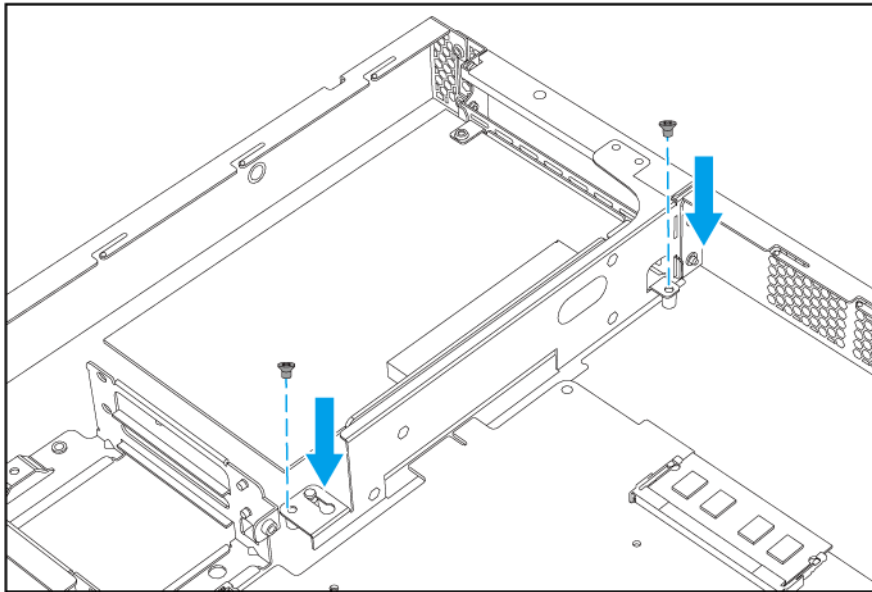

d. 鎖上背部面板螺絲。

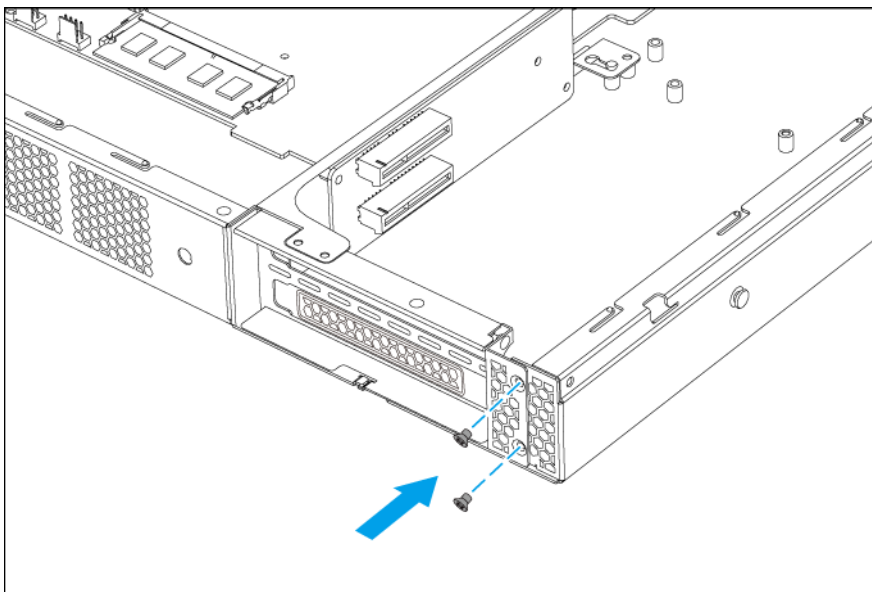

9. 裝上機殼蓋。
如需詳細資訊，請參見：[裝上機殼蓋](#)。
10. 連上所有連接線和外接裝置。
11. 將電源線插入電源插座。
12. 打開交換器電源。

安裝橡膠腳座至交換器

1. 關閉交換器電源。

2. 從電源插座拔下電源線。
3. 中斷所有連接線和外接裝置的連線。
4. 將交換器上下翻轉。

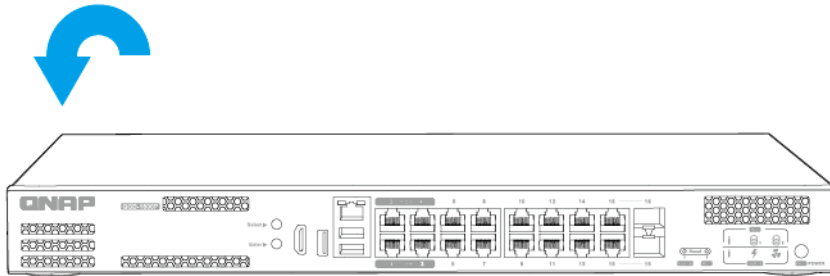

5. 裝上橡膠腳座。
 - a. 將橡膠腳座的保護膜取下。
 - b. 裝上橡膠腳座。

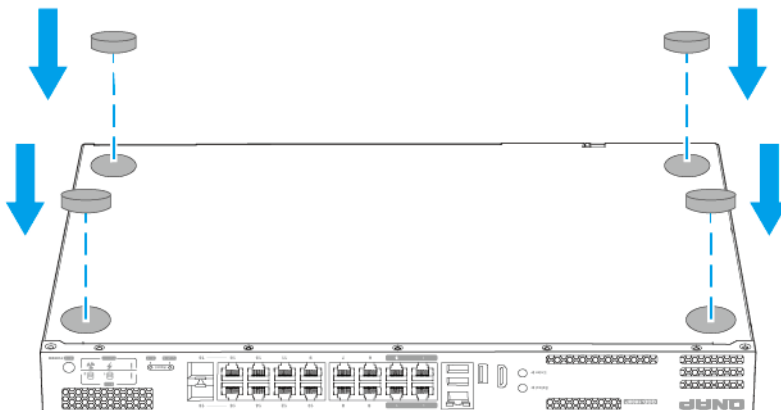

- c. 將交換器正常直立。

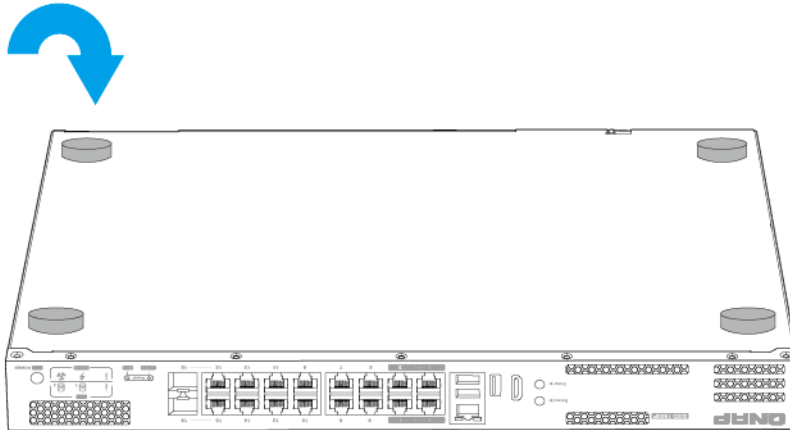

6. 連上所有連接線和外接裝置。
7. 將電源線插入電源插座。
8. 打開交換器電源。

安裝交換器支架

QGD-1600P 套件包含前端安裝支架，可將交換器安裝到機架上。交換器與下列機架滑軌型號和配件相容：

- RAIL-B02
- SP-EAR-BLK-01

交換器不含機架滑軌及配件，必須另外購買。如需詳細資訊，請聯絡授權經銷商或前往 <http://shop.qnap.com>。



提示

- QNAP 建議安裝完所有其他硬體，再將交換器安裝至機架。
 - QNAP 建議安裝完交換器至有良好通風的機架。
1. 關閉交換器電源。
 2. 從電源插座拔下電源線。
 3. 中斷所有連接線和外接裝置的連線。
 4. 在交換器上安裝角形托座。
 - a. 將角形托座上的孔洞對齊機殼上的孔洞。
 - b. 鎖上用於固定支架至交換器的螺絲。

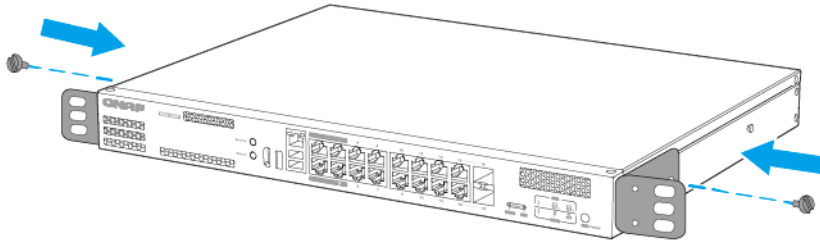

連接交換器至電腦或網路

QGD-1600P 可以連接至電腦或區域網路。如需詳細資訊，請參見下列主題：

- [連接交換器至電腦](#)
- [連接交換器至網路](#)

連接交換器至電腦

您可透過將乙太網路線連接至交換器上的 PoE 連接埠，將 QGD-1600P 連接至 QNAP NAS，來擴充儲存容量並將資料備份至另一台 NAS。但是您必須將 QGD-1600P 連接至電腦來配置交換器設定。

1. 打開交換器電源。
2. 連接交換器至電腦。
 - a. 將乙太網路連接線連接至交換器上的 PoE 連接埠。
 - b. 將乙太網路連接線連接至電腦上的 Gigabit 乙太網路埠。

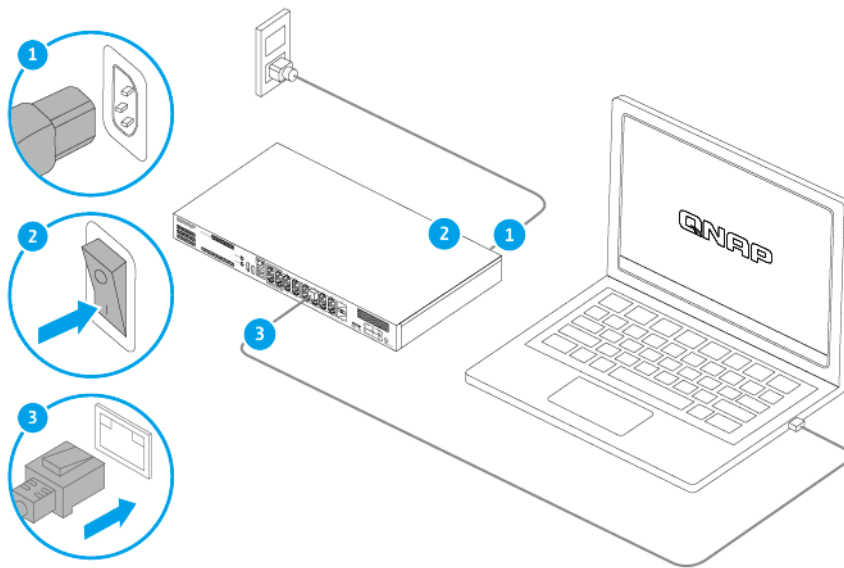

3. 確認電腦可辨識交換器。
 - a. 在主機電腦中開啟 Qfinder Pro。

**注意**

若要下載 Qfinder Pro，請前往 <https://www.qnap.com/utilities>。

- b. 從清單中尋找交換器。

連接交換器至網路

QGD-1600P 可透過主機連接埠或 PoE 連接埠連接至區域網路。

1. 打開交換器電源。
2. 透過下列其中一種連接埠類型，將交換器連接至區域網路。

類型	方法
主機連接埠	在 LCD 面板上選擇於 Adapter 1 取得的 IP 位址。
PoE 連接埠	在 LCD 面板上選擇於 Adapter 2 或 Adapter 3 取得的 IP 位址。

3. 在連接相同區域網路的電腦上執行 Qfinder Pro。

**注意**

若要下載 Qfinder Pro，請前往 <https://www.qnap.com/utilities>。

4. 在 Qfinder Pro 搜尋列輸入 IP 位址。
5. 在清單中找到交換器，然後在名稱或 IP 位址上按兩下。
QTS 登入畫面隨即出現。
6. 輸入 QTS 登入資訊。
7. 按一下 [登入]。

連接 USB 擴充設備

QGD-1600P 支援 USB 擴充設備。詳細資訊請參考下表：

如需相容擴充設備清單以及適用擴充設備的數量上限，請前往：<http://www.qnap.com/go/compatibility-expansion>。

您可以向 QNAP 或授權經銷商購買儲存擴充配件。

如需詳細資訊，請瀏覽：<https://shop.qnap.com/>。

擴充設備型號	說明	必要配件
TR-002	<ul style="list-style-type: none"> 使用 USB 3.2 Gen 2 Type-C 介面 支援 SATA 硬碟 	<ul style="list-style-type: none"> USB 3.2 Gen 2 Type-A 轉 Type-C 連接線 USB 3.2 Gen 2 Type-C 轉 Type-C 連接線
TR-004	<ul style="list-style-type: none"> 使用 USB 3.2 Gen 1 Type-C 介面 支援 SATA 硬碟 	<ul style="list-style-type: none"> USB 3.2 Gen 2 Type-A 轉 Type-C 連接線 USB 3.2 Gen 2 Type-C 轉 Type-C 連接線
TR-004U		<ul style="list-style-type: none"> USB 3.2 Gen 1 Type-A 轉 Type-C 連接線 USB 3.2 Gen 2 Type-C 轉 Type-C 連接線 RAIL-B02

1. 將擴充設備連接至交換器。
 - a. 將 USB 連接線接至擴充設備上的 USB Type-C 連接埠。
 - b. 將 USB 連接線連接至交換器上的 USB Type-A 連接埠。

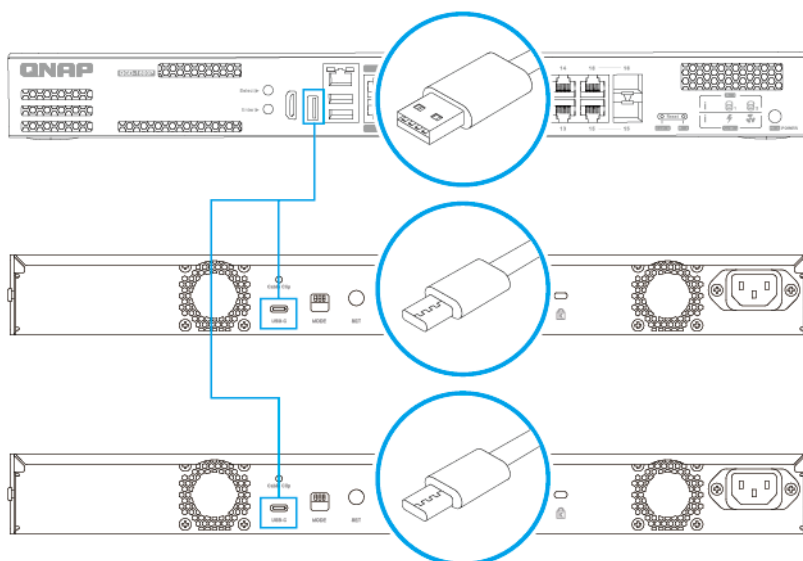

2. 開啟擴充設備的電源。
3. 確認交換器可辨識所有擴充設備。
 - a. 請以管理員身分登入 QTS。
 - b. 前往 [主選單] > [儲存與快照總管] > [總覽] > [系統]。
 - c. 確認畫面列出擴充設備。

QTS 安裝

安裝方法	說明	需求
Qfinder Pro (建議使用)	如果交換器已連接至區域網路，您可以執行下列操作： <ul style="list-style-type: none"> • 使用 Qfinder Pro 定位交換器。 • 完成「智慧安裝導引」精靈中的步驟。 	<ul style="list-style-type: none"> • 電腦 • 網路線 • Qfinder Pro 安裝程式
雲端	如果交換器已連接至網際網路，您可以執行下列操作： <ul style="list-style-type: none"> • 掃描交換器上的 QR 碼。 • 指定 Cloud Key。 • 登入 myQNAPcloud 帳號。 • 使用 myQNAPcloud Link 遠端存取交換器。 • 完成「智慧安裝導引」精靈中的步驟。 	<ul style="list-style-type: none"> • 電腦或行動裝置。 • myQNAPcloud 帳號 • Cloud Key
本機	如果交換器支援 HDMI 輸出，您可以執行下列操作： <ul style="list-style-type: none"> • 將交換器連接至所需的硬碟。 • 完成「智慧安裝導引」精靈中的步驟。 	<ul style="list-style-type: none"> • 監控器 • HDMI 連接線 • USB 鍵盤或遙控器 (並非所有型號皆有提供)

使用 Qfinder Pro 安裝 QTS



警告

安裝 QTS 會刪除硬碟上的所有資料。繼續操作前請先備份資料。

1. 打開交換器電源。
2. 將交換器連接至區域網路。



提示

您可透過主機連接埠或任何 PoE 連接埠來連接至區域網路。

3. 在連接相同區域網路的電腦上執行 Qfinder Pro。

**注意**

若要下載 Qfinder Pro，請前往 <https://www.qnap.com/utilities>。

4. 在清單中找到交換器，然後在名稱或 IP 位址上按兩下。
「智慧安裝導引」隨即在預設的網頁瀏覽器中開啟。
5. 按一下 [啟動智慧安裝導引]。
6. 輸入下列資訊：
 - **NAS 名稱**：輸入 1 到 14 個字元的名稱。名稱支援使用英文字母 (A 到 Z、a 到 z)、數字 (0 到 9) 以及連字號 (-)，但不能以連字號做結尾。
 - **密碼**：指定 1 到 64 個字元的管理員密碼。密碼支援使用所有 ASCII 字元。
7. 按一下 [下一步]。
8. 指定時區、日期和時間。

**提示**

QNAP 建議連接至 NTP 伺服器，以確保交換器符合國際標準時間 (UTC) 的標準。

9. 按一下 [下一步]。
10. 選擇 [自動取得 IP 位址 (DHCP)]。
11. 按一下 [下一步]。
12. 選擇將用於存取交換器共用資料夾的裝置類型。
13. 按一下 [下一步]。
14. 檢視設定值。
15. 按一下 [套用]。
確認訊息隨即出現。

**警告**

按一下 [確認] 後，系統會在安裝 QTS 前刪除硬碟的所有資料。

16. 按一下 [確認]。
QTS 安裝完成。

使用 Cloud Key 安裝 QTS

**警告**

安裝 QTS 會刪除硬碟上的所有資料。繼續操作前請先備份資料。

1. 打開交換器電源。
2. 將交換器連接至網際網路。
3. 使用下列其中一種方式前往 QNAP 雲端安裝頁面：
 - 使用電腦前往 <http://install.qnap.com/>。
 - 使用行動裝置掃描交換器上的 QR 碼。

該網頁列出區域網路內所有未初始化的 QNAP 裝置。

4. 在清單中找到自己的交換器，然後按一下 [初始化] 。

**注意**

如果未列出您的交換器，請按照網頁上的指示來指定交換器的 Cloud Key 。

安裝精靈隨即在預設的網頁瀏覽器中開啟。

5. 建立帳號或登入 myQNAPcloud 。

**注意**

您建立帳號之後，必須返回此頁面完成安裝步驟。

6. 指定交換器的 myQNAPcloud 裝置名稱。

**注意**

- 遠端存取交換器時，需要用到 myQNAPcloud 裝置名稱。
- 基於安全考量，交換器將於初始化後停用 myQNAPcloud Link 遠端連線服務。日後若要再度啟用，請透過區域網路連接至 QTS，然後安裝 myQNAPcloud Link 。

7. 按一下 [下一步] 。
- 「智慧安裝導引」隨即在預設的網頁瀏覽器中開啟。

8. 按一下 [啟動智慧安裝導引] 。

9. 輸入下列資訊：

- **NAS 名稱**：輸入 1 到 14 個字元的名稱。名稱支援使用英文字母 (A 到 Z、a 到 z)、數字 (0 到 9) 以及連字號 (-)，但不能以連字號做結尾。
- **密碼**：指定 1 到 64 個字元的管理員密碼。密碼支援使用所有 ASCII 字元。

10. 按一下 [下一步] 。

11. 指定時區、日期和時間。

**提示**

QNAP 建議連接至 NTP 伺服器，以確保交換器符合國際標準時間 (UTC) 的標準。

12. 按一下 [下一步] 。

13. 選擇 [自動取得 IP 位址 (DHCP)] 。

14. 按一下 [下一步] 。

15. 選擇將用於存取交換器共用資料夾的裝置類型。

16. 按一下 [下一步] 。

17. 檢視設定值。

18. 按一下 [套用] 。
- 確認訊息隨即出現。

**警告**

按一下 [確認] 後，系統會在安裝 QTS 前刪除硬碟的所有資料。

19. 按一下 [確認] 。

QTS 安裝完成。

使用 HDMI 連線安裝 QTS



警告

安裝 QTS 會刪除硬碟上的所有資料。繼續操作前請先備份資料。

1. 連接 HDMI 顯示器到交換器。
2. 將 USB 鍵盤連接至交換器，或準備 QNAP 紅外線 (IR) 遙控器 (並非所有型號皆提供)。
3. 打開交換器電源。
[智慧安裝導引] 的歡迎畫面隨即出現。
4. 選擇 [啟動智慧安裝導引]。
5. 選擇 [否，略過這個程序]。
若啟用多媒體功能，您就能在 [儲存與快照總管] 中設定硬碟之後，安裝多媒體應用程式。
如需在 QTS 啟用多媒體功能的詳細資訊，請參見《QTS 使用者指南》的 < 系統管理 > 一節。
6. 選擇 [稍後設定]。
如需設定硬碟的詳細資訊，請參見《QTS 使用者指南》的 < 儲存與快照總管 > 一節。
7. 檢視設定值。
8. 按一下 [下一步]。
9. 檢視設定值。
10. 按一下 [下一步]。
確認畫面隨即出現。



警告

按一下 [下一步] 後，系統會在安裝 QTS 前刪除硬碟的所有資料。

11. 按一下 [下一步]。
QTS 安裝完成。

交換器管理應用程式存取

您可以透過以下應用程式管理 QGD-1600P 交換器：

應用程式	描述
QuNetSwitch	QTS 交換器管理應用程式。QTS 已預先安裝 QuNetSwitch。
QSS	QNAP 交換器的交換器管理系統。QSS 預先安裝於交換器。

如需詳細資訊，請參見下列主題：

- [在 QTS 存取 QuNetSwitch](#)
- [透過 Qfinder Pro 存取 QSS](#)

在 QTS 存取 QuNetSwitch



注意

您必須在使用 QuNetSwitch 前建立預設系統磁碟區。
如需詳細資料，請參見《QTS 使用者指南》。

1. 打開交換器電源。
2. 登入 QTS。



注意

如需詳細資料，請參見：[連接交換器至網路](#)。

3. 前往 [主選單] > [QuNetSwitch]。
4. 繼續管理交換器。



注意

如需交換器管理的詳細資訊，請參見《QuNetSwitch 使用者指南》。

透過 Qfinder Pro 存取 QSS



注意

您必須在使用 QuNetSwitch 前建立預設系統磁碟區。

1. 打開交換器電源。
2. 將交換器連接至區域網路。
如需詳細資料，請參見：[連接交換器至網路](#)。
3. 在連接相同區域網路的電腦上執行 Qfinder Pro。



注意

若要下載 Qfinder Pro，請前往 <https://www.qnap.com/utilities>。

4. 輸入交換器 IP 位址。
交換器 IP 位址將顯示為 %您的 NAS 名稱%- 交換器。
5. 在清單中找到交換器，然後在名稱或 IP 位址上按兩下。
QSS 登入畫面隨即出現。
6. 登入 QSS。
QSS 預設登入詳細資料如下：
 - 帳戶名稱：admin
 - 密碼：admin
 [歡迎] 視窗隨即出現。
7. 輸入下列資訊：
 - **NAS 名稱**：輸入 1 到 14 個字元的名稱。名稱支援使用英文字母 (A 到 Z、a 到 z)、數字 (0 到 9) 以及連字號 (-)，但不能以連字號做結尾。
 - **密碼**：指定 1 到 64 個字元的管理員密碼。密碼支援使用所有 ASCII 字元。
8. 繼續管理交換器。



注意

如需交換器管理的詳細資訊，請參見《QuNetSwitch 使用者指南》。

4. 基本操作

本章介紹交換器的基本操作。

按鈕

主機電源按鈕

操作	使用者動作	結果
開啟電源	按一下按鈕。	交換器啟動並登入 QTS。
關閉電源	按住按鈕 1.5 秒。	交換器關閉並登出 QTS。
強制關機	按住按鈕 5 秒。	交換器關機。

 **重要**
請在交換器沒有回應時才使用此方法。

交換器重設按鈕

操作	使用者動作	結果
重設	按住按鈕 3 秒。	交換器隨即重設並還原所有預設設定。

QTS 重設按鈕

操作	使用者動作	結果
系統基本重置	按住按鈕 3 秒。	以下 QTS 設定將還原為預設設定： <ul style="list-style-type: none"> • 系統管理員密碼：admin • TCP/IP 設定：透過 DHCP 自動取得 IP 位址設定。 • 停用 Jumbo Frame。 • 若已啟用 Port Trunking (僅適用於支援多 LAN 的型號)，系統將重設為「Active Backup (網路容錯)」模式。 • 系統通訊埠：8080 (系統服務埠) • 安全等級：低 (接受所有連線) • LCD 面板密碼：(空白) • VLAN：已停用
系統進階重置	按住按鈕 15 秒。	回復為 QTS 預設值。 <div style="border: 1px solid black; padding: 5px; margin-top: 10px;">  提示 若要在系統進階重設後取得舊有資料，請在交換器上重建先前的資料夾結構。 </div>

LCD 面板

檢視 TCP/IP 設定

您可以在交換器上檢視每個網路介面卡的下列設定：

- IP 位址
 - 子網路遮罩
 - 預設閘道
 - 主要 DNS
 - 次要 DNS
1. 按下 [**Enter (進入)**] 或 [**Select (選擇)**] 。
面板會顯示交換器名稱與 QTS 版本。
 2. 按住 [**Enter (進入)**] 兩秒。
面板會顯示 [Main Menu 1. TCP/IP (主選單 1. TCP/IP)] 。
 3. 按住 [**Enter (進入)**] 。
面板隨即顯示第一個網路介面卡的 IP 位址。
 4. 按下 [**Select (選擇)**] 以檢視下一個 TCP/IP 畫面。
 5. 選擇性: 依需要重複執行步驟 4。

配置 TCP/IP 設定

您可以在交換器上配置每個網路介面卡的下列設定：

- IP 位址
 - 子網路遮罩
 - 預設閘道
 - 主要 DNS
 - 次要 DNS
1. 按下 [**Enter (進入)**] 或 [**Select (選擇)**] 。
面板會顯示 NAS 名稱與 QTS 版本。
 2. 按住 [**Enter (進入)**] 兩秒
面板會顯示 [Main Menu 1. TCP/IP (主選單 1. TCP/IP)] 。
 3. 按住 [**Enter (進入)**] 。
面板隨即顯示第一個網路介面卡的 IP 位址。
 4. 重複按 [**Select (選擇)**] ，直到面板顯示 [Enter Network Settings (輸入網路設定)] 。
 5. 按住 [**Enter (進入)**] 。
面板隨即顯示可配置的網路設定。
 6. 按下 [**Select (選擇)**] 和 [**Enter (進入)**] 以配置設定。

按鈕	用途
進入	<ul style="list-style-type: none"> 顯示設定畫面。 移至設定畫面的下一個項目。
選擇	<ul style="list-style-type: none"> 移至選單的下一個項目。 修改設定畫面上的值。

檢視硬碟資訊

LCD 面板可顯示交換器每個已安裝硬碟的溫度與容量。

1. 按下 [**Enter (進入)**] 或 [**Select (選擇)**] 。
面板會顯示交換器名稱與 QTS 版本。
2. 按住 [**Enter (進入)**] 兩秒。
面板會顯示 [Main Menu 1. TCP/IP (主選單 1. TCP/IP)] 。
3. 重複按 [**Enter (進入)**] ，直到面板顯示 [Main Menu 2. Physical disk (主選單 2. 實體硬碟)] 。
4. 按住 [**Enter (進入)**] 。
面板隨即顯示插槽 1 的硬碟溫度與容量。
5. 按住 [**Select (選擇)**] 。
面板隨即顯示下一個硬碟的溫度與容量。
6. 選擇性: 依需要重複執行步驟 5 。

檢視系統資訊

LCD 面板可顯示 CPU 溫度、系統溫度以及系統風扇轉速。

1. 按下 [**Enter (進入)**] 或 [**Select (選擇)**] 。
面板會顯示交換器名稱與 QTS 版本。
2. 按住 [**Enter (進入)**] 兩秒。
面板會顯示 [Main Menu 1. TCP/IP (主選單 1. TCP/IP)] 。
3. 重複按 [**Enter (進入)**] ，直到面板顯示 [Main Menu 4. System (主選單 4. 系統)] 。
4. 按住 [**Enter (進入)**] 。
面板隨即顯示 CPU 與系統溫度。
5. 按住 [**Select (選擇)**] 。
面板隨即顯示系統風扇轉速。

關閉交換器電源

1. 按下 [**Enter (進入)**] 或 [**Select (選擇)**] 。
面板會顯示交換器名稱與 QTS 版本。
2. 按住 [**Enter (進入)**] 兩秒。
面板會顯示 [Main Menu 1. TCP/IP (主選單 1. TCP/IP)] 。
3. 重複按 [**Enter (進入)**] ，直到面板顯示 [Main Menu 5. Shut down (主選單 5. 關機)] 。

4. 按住 [**Enter (進入)**] 。
交換器隨即關機。

重新啟動交換器

1. 按下 [**Enter (進入)**] 或 [**Select (選擇)**] 。
面板會顯示交換器名稱與 QTS 版本。
2. 按住 [**Enter (進入)**] 兩秒。
面板會顯示 [Main Menu 1. TCP/IP (主選單 1. TCP/IP)] 。
3. 重複按 [**Enter (進入)**] ，直到面板顯示 [Main Menu 6. Reboot (主選單 6. 重新啟動)] 。
4. 按住 [**Enter (進入)**] 。
交換器隨即重新啟動。

變更 LCD 密碼

指定 LCD 面板的密碼，以防止他人未經授權進行存取。

1. 按下 [**Enter (進入)**] 或 [**Select (選擇)**] 。
面板會顯示交換器名稱與 QTS 版本。
2. 按住 [**Enter (進入)**] 兩秒。
面板會顯示 [Main Menu 1. TCP/IP (主選單 1. TCP/IP)] 。
3. 重複按 [**Enter (進入)**] ，直到面板顯示 [Main Menu 7. Password (主選單 7. 密碼)] 。
4. 按住 [**Enter (進入)**] 。
[Change Password (密碼變更)] 畫面隨即出現。
5. 選擇 [**Yes (是)**] (按住 [**Enter (進入)**]) 。
[New Password (新密碼)] 畫面隨即出現。
6. 按下 [**Select (選擇)**] 和 [**Enter (進入)**] 來設定新密碼。
 - 設定密碼。
 - 指定 1 到 8 個字元的密碼。密碼僅限數字 (0 到 9) 。
 - 若不要設定密碼，密碼欄位請留空白。

按鈕	用途
Enter (進入)	在 [New Password (新密碼)] 畫面中移到下一個項目。
Select (選擇)	在 [New Password (新密碼)] 與 [Verify Password (確認密碼)] 畫面中變更數字。

7. 按下 [**Enter (進入)**] 。
交換器即會儲存密碼。

LCD 錯誤訊息

系統訊息	描述
Sys. Fan Failed (系統風扇故障)	系統風扇發生故障。

系統訊息	描述
Sys. Overheat (系統過熱)	系統溫度過高。
HDD Overheat (硬碟過熱)	硬碟溫度過高。
CPU Overheat (CPU 過熱)	CPU 溫度過高。
Network Lost (網路中斷)	LAN1、LAN2、LAN3 及 LAN4 在容錯或負載平衡模式下中斷連線。
LAN1 Lost (LAN1 中斷)	LAN1 已中斷連線。
LAN2 Lost (LAN2 中斷)	LAN2 已中斷連線。
LAN3 Lost (LAN3 中斷)	LAN3 已中斷連線。
LAN4 Lost (LAN4 中斷)	LAN4 已中斷連線。
HDD Failure (硬碟故障)	硬碟異常。
Vol1 Full (Vol1 已滿)	容量已滿。
HDD Ejected (硬碟已退出)	硬碟已退出。
Vol1 Degraded (Vol1 已降階)	Volume1 處於降階模式。
Vol1 Unmounted (Vol1 已卸載)	Volume1 已卸載。
Vol1 Nonactive (Vol1 未啟用)	Volume1 處於未啟用狀態。

LED 燈號

LED 燈號指示交換器開機時的系統狀態與相關資訊。下列 LED 燈號資訊僅適用於已正確安裝硬碟，且交換器已連線至網路的狀態下。

如需 LED 燈號的位置資訊，請參見：[前方面板](#)。

LED	狀態	說明
主機電源	綠燈	主機系統已就緒。
	每 1.0 秒閃爍綠色燈號	主機系統啟動中。
	紅燈	主機系統發生嚴重錯誤。
	關閉	主機系統已關機。
硬碟 1	綠燈	硬碟運作正常。
	紅燈	發生錯誤。
	關閉	偵測不到硬碟。
硬碟 2	綠燈	硬碟運作正常。
	紅燈	發生錯誤。
	關閉	偵測不到硬碟。
交換器電源	綠燈	交換器就緒。
	每 1.0 秒閃爍綠色燈號	交換器啟動中。
	紅燈	交換器系統發生嚴重錯誤。
	關閉	交換器系統已關機。
PoE	綠燈	PoE 狀態正常。
	紅燈	PoE 發生嚴重錯誤。
風扇	綠燈	風扇狀態正常。
	紅燈	風扇發生嚴重錯誤。

LED	狀態	說明
PoE 連接埠速度	每 1.0 秒閃爍綠色燈號	連結速度為 1 Gbps。
	每 1.0 秒閃爍琥珀色燈號	連線速度為 10/100 Mbps。
	關閉	未偵測到連線。
PoE 連接埠活動 / 連結	綠燈	交換器已連接至電源裝置。
	琥珀色燈	電源裝置發生錯誤。
	關閉	沒有偵測到任何電源裝置。
複合式連接埠速度	每 1.0 秒閃爍綠色燈號	連結速度為 1 Gbps。
	每 1.0 秒閃爍琥珀色燈號	連線速度為 10/100 Mbps。
	關閉	未偵測到連線。
複合連接埠活動 / 連結	每 1.0 秒閃爍琥珀色燈號	正在傳輸資料。

警示音

長度	頻率	描述
短嗶 (0.5 秒)	1	<ul style="list-style-type: none"> 裝置啟動中。 裝置關閉中 (軟體關機)。 使用者按下「交換器重設」按鈕。 作業系統已更新。
長嗶 (1.5 秒)	3 聲 (每 5 分鐘)	系統風扇異常。
	2	<ul style="list-style-type: none"> 磁碟區容量將滿。 磁碟區容量已滿。 硬碟進入降階模式。 使用者開始硬碟重建程序。 硬碟已中斷連線或已連接。
	1	<ul style="list-style-type: none"> 裝置強制關機 (硬體關機)。 裝置成功開機且已就緒。
長嗶 (5 秒)	1	QTS 正在重新啟動。

5. 疑難排解

本章介紹基本的疑難排解資訊。

熱插拔故障硬碟

交換器於下列情況支援硬碟熱插拔：

- RAID 1：一個硬碟故障
- RAID 5：一個硬碟故障
- RAID 6：一個或兩個硬碟故障

1. 登入 QTS。
2. 前往 [主選單] > [儲存與快照總管] > [儲存空間] > [磁碟/VJBOD]。
3. 找出故障的硬碟。
4. 準備一個新的硬碟，且容量至少與故障硬碟相同。
5. 將交換器的故障硬碟拔出。
6. 等待 20 秒或等待交換器發出兩次嗶聲。
7. 將故障硬碟從硬碟托盤取下。
8. 將新的硬碟插入硬碟托盤。
9. 安裝新的硬碟。
交換器會發出兩次嗶聲。
10. 前往 [主選單] > [儲存與快照總管] > [儲存空間]。
11. 找出新硬碟所在的磁碟區，然後確認其狀態為 [重建中]。

強制 Qfinder Pro 以及 myQNAPcloud 定位交換器

如果 Qfinder Pro 或 myQNAPcloud 在 QTS 安裝期間找不到交換器，表示硬碟或資料發生問題。

1. 關閉交換器電源。
2. 移除所有硬碟。
3. 打開交換器電源。
4. 使用 Qfinder Pro 定位交換器。
5. 將硬碟重新插入。
6. 繼續執行 QTS 安裝作業。

支援和其他資源

QNAP 提供下列資源：

資源	URL
文件	https://docs.qnap.com
服務入口網站	https://service.qnap.com
下載	https://download.qnap.com
社群論壇	https://forum.qnap.com

6. 詞彙

myQNAPcloud

提供各種遠端存取服務，例如 DDNS 與 myQNAPcloud Link

myQNAPcloud Link

讓您透過網際網路存取 NAS，無需配置複雜的連接埠轉址設定

Qfinder Pro

QNAP 應用工具可讓您定位和存取區域網路內的 QNAP NAS 裝置

QuNetSwitch

執行 QTS 作業系統的 QNAP 交換器管理應用程式

QTS

QNAP NAS 作業系統

QSS

QNAP 交換器管理應用程式

7. 聲明

本章介紹擔保、免責聲明、授權以及聯辦法規的相關資訊。

有限保固

QNAP 提供有限的產品保固服務。您購買的 QNAP 品牌硬體產品在材料和製造品質上受到瑕疵擔保，擔保期限為發票上所印日期起一 (1) 年或以上。("保固期")。請前往 www.qnap.com/warranty 深入瞭解您的法定權利，然 QNAP 得自行酌情隨時予以修改。

免責聲明

本文件所含資訊的適用對象為 QNAP Systems, Inc. (下稱 "QNAP") 之產品。本文並未以明示、默示、禁反言或其他方式授予任何智慧財產權。除 QNAP 產品銷售條款與條件另有規定外，QNAP 不承擔任何責任，且 QNAP 免除任何與 QNAP 產品銷售及 / 或使用有關的明示或默示之保固，包括符合特定用途、商業適售性的責任與保固，以及侵害任何專利、版權或其他智慧財產權之行為。

QNAP 產品不適用於醫療、救生、生命維持、重要管制點或安全系統，也不適用於核能設施應用。

在任何情況下，QNAP 對於因使用產品、其隨附軟體或其文件所造成的直接、間接、特殊、附帶或衍生損壞，應負擔的賠償責任不超過本產品的售價。QNAP 對其產品或本文件之內容或應用以及所有隨附軟體，不做任何明示、默示或法定之保證或表述，亦特別聲明，不保證其品質、效能、適售性或適用於任何特定用途。QNAP 保留修訂或更新其產品、軟體或文件的權利，如有變更，恕不另行通知。

建議定期備份系統資料，以避免發生任何資料遺失意外。QNAP 不負責任何資料遺失或復原。

如要把 NAS (網路儲存裝置) 等 QNAP 產品包裝內的任何元件退回，並要求退款或維修，請確定貨品已妥善包裝以利運送。若貨品運送期間因不妥善包裝造成任何損壞，QNAP 一概不予負責。

本公司保留變更產品功能與規格的權利，如有變更，恕不另行通知。本文資訊如有變更，恕不另行通知。

另外，本文省略 ® 或 ™ 符號。

GNU Public License

Version 3, 29 June 2007

Everyone is permitted to copy and distribute verbatim copies of this license document, but changing it is not allowed.

Preamble

The GNU General Public License is a free, copy left license for software and other kinds of works.

The licenses for most software and other practical works are designed to take away your freedom to share and change the works. By contrast, the GNU General Public License is intended to guarantee your freedom to share and change all versions of a program--to make sure it remains free software for all its users. We, the Free Software Foundation, use the GNU General Public License for most of our software; it applies also to any other work released this way by its authors. You can apply it to your programs, too.

When we speak of free software, we are referring to freedom, not price. Our General Public Licenses are designed to make sure that you have the freedom to distribute copies of free software (and charge for them if you wish), that you receive source code or can get it if you want it, that you can change the software or use pieces of it in new free programs, and that you know you can do these things.

To protect your rights, we need to prevent others from denying you these rights or asking you to surrender the rights. Therefore, you have certain responsibilities if you distribute copies of the software, or if you modify it: responsibilities to respect the freedom of others.

For example, if you distribute copies of such a program, whether gratis or for a fee, you must pass on to the recipients the same freedoms that you received. You must make sure that they, too, receive or can get the source code. And you must show them these terms so they know their rights.

Developers that use the GNU GPL protect your rights with two steps: (1) assert copyright on the software, and (2) offer you this License giving you legal permission to copy, distribute and/or modify it.

For the developers' and authors' protection, the GPL clearly explains that there is no warranty for this free software. For both users' and authors' sake, the GPL requires that modified versions be marked as changed, so that their problems will not be attributed erroneously to authors of previous versions.

Some devices are designed to deny users access to install or run modified versions of the software inside them, although the manufacturer can do so. This is fundamentally incompatible with the aim of protecting users' freedom to change the software. The systematic pattern of such abuse occurs in the area of products for individuals to use, which is precisely where it is most unacceptable. Therefore, we have designed this version of the GPL to prohibit the practice for those products. If such problems arise substantially in other domains, we stand ready to extend this provision to those domains in future versions of the GPL, as needed to protect the freedom of users.

Finally, every program is threatened constantly by software patents. States should not allow patents to restrict development and use of software on general-purpose computers, but in those that do, we wish to avoid the special danger that patents applied to a free program could make it effectively proprietary. To prevent this, the GPL assures that patents cannot be used to render the program non-free.

The precise terms and conditions for copying, distribution and modification follow.

Terms and Conditions

1. Definitions.

"This License" refers to version 3 of the GNU General Public License.

"Copyright" also means copyright-like laws that apply to other kinds of works, such as semiconductor masks.

"The Program" refers to any copyrightable work licensed under this License. Each licensee is addressed as "you". "Licensees" and "recipients" may be individuals or organizations. To "modify" a work means to copy from or adapt all or part of the work in a fashion requiring copyright permission, other than the making of an exact copy. The resulting work is called a "modified version" of the earlier work or a work "based on" the earlier work.

A "covered work" means either the unmodified Program or a work based on the Program.

To "propagate" a work means to do anything with it that, without permission, would make you directly or secondarily liable for infringement under applicable copyright law, except executing it on a computer or modifying a private copy. Propagation includes copying, distribution (with or without modification), making available to the public, and in some countries other activities as well.

To "convey" a work means any kind of propagation that enables other parties to make or receive copies. Mere interaction with a user through a computer network, with no transfer of a copy, is not conveying.

An interactive user interface displays "Appropriate Legal Notices" to the extent that it includes a convenient and prominently visible feature that (1) displays an appropriate copyright notice, and (2) tells the user that there is no warranty for the work (except to the extent that warranties are provided), that licensees may convey the work under this License, and how to view a copy of this License. If the interface presents a list of user commands or options, such as a menu, a prominent item in the list meets this criterion.

2. Source Code.

The “source code” for a work means the preferred form of the work for making modifications to it.

“Object code” means any non-source form of a work.

A “Standard Interface” means an interface that either is an official standard defined by a recognized standards body, or, in the case of interfaces specified for a particular programming language, one that is widely used among developers working in that language.

The “System Libraries” of an executable work include anything, other than the work as a whole, that (a) is included in the normal form of packaging a Major Component, but which is not part of that Major Component, and (b) serves only to enable use of the work with that Major Component, or to implement a Standard Interface for which an implementation is available to the public in source code form. A

“Major Component”, in this context, means a major essential component (kernel, window system, and so on) of the specific operating system (if any) on which the executable work runs, or a compiler used to produce the work, or an object code interpreter used to run it.

The “Corresponding Source” for a work in object code form means all the source code needed to generate, install, and (for an executable work) run the object code and to modify the work, including scripts to control those activities. However, it does not include the work’s System Libraries, or general-purpose tools or generally available free programs which are used unmodified in performing those activities but which are not part of the work. For example, Corresponding Source includes interface definition files associated with source files for the work, and the source code for shared libraries and dynamically linked subprograms that the work is specifically designed to require, such as by intimate data communication or control flow between those subprograms and other parts of the work.

The Corresponding Source need not include anything that users can regenerate automatically from other parts of the Corresponding Source.

The Corresponding Source for a work in source code form is that same work.

3. Basic Permissions.

All rights granted under this License are granted for the term of copyright on the Program, and are irrevocable provided the stated conditions are met. This License explicitly affirms your unlimited permission to run the unmodified Program. The output from running a covered work is covered by this License only if the output, given its content, constitutes a covered work. This License acknowledges your rights of fair use or other equivalent, as provided by copyright law.

You may make, run and propagate covered works that you do not convey, without conditions so long as your license otherwise remains in force. You may convey covered works to others for the sole purpose of having them make modifications exclusively for you, or provide you with facilities for running those works, provided that you comply with the terms of this License in conveying all material for which you do not control copyright. Those thus making or running the covered works for you must do so exclusively on your behalf, under your direction and control, on terms that prohibit them from making any copies of your copyrighted material outside their relationship with you.

Conveying under any other circumstances is permitted solely under the conditions stated below.

Sublicensing is not allowed; section 10 makes it unnecessary.

4. Protecting Users' Legal Rights From Anti-Circumvention Law.

No covered work shall be deemed part of an effective technological measure under any applicable law fulfilling obligations under article 11 of the WIPO copyright treaty adopted on 20 December 1996, or similar laws prohibiting or restricting circumvention of such measures.

When you convey a covered work, you waive any legal power to forbid circumvention of technological measures to the extent such circumvention is effected by exercising rights under this License with respect to the covered work, and you disclaim any intention to limit operation or modification of the work as a means of enforcing, against the work’s users, your or third parties’ legal rights to forbid circumvention of technological measures.

5. Conveying Verbatim Copies.

You may convey verbatim copies of the Program’s source code as you receive it, in any medium, provided that you conspicuously and appropriately publish on each copy an appropriate copyright notice; keep intact all notices stating that this License and any non-permissive terms added in accord with section 7 apply to the code; keep intact all notices of the absence of any warranty; and give all recipients a copy of this License along with the Program.

You may charge any price or no price for each copy that you convey, and you may offer support or warranty protection for a fee.

6. Conveying Modified Source Versions.

You may convey a work based on the Program, or the modifications to produce it from the Program, in the form of source code under the terms of section 4, provided that you also meet all of these conditions:

- a. The work must carry prominent notices stating that you modified it, and giving a relevant date.
- b. The work must carry prominent notices stating that it is released under this License and any conditions added under section 7. This requirement modifies the requirement in section 4 to “keep intact all notices” .
- c. You must license the entire work, as a whole, under this License to anyone who comes into possession of a copy. This License will therefore apply, along with any applicable section 7 additional terms, to the whole of the work, and all its parts, regardless of how they are packaged. This License gives no permission to license the work in any other way, but it does not invalidate such permission if you have separately received it.
- d. If the work has interactive user interfaces, each must display Appropriate Legal Notices; however, if the Program has interactive interfaces that do not display Appropriate Legal Notices, your work need not make them do so.
A compilation of a covered work with other separate and independent works, which are not by their nature extensions of the covered work, and which are not combined with it such as to form a larger program, in or on a volume of a storage or distribution medium, is called an “aggregate” if the compilation and its resulting copyright are not used to limit the access or legal rights of the compilation's users beyond what the individual works permit. Inclusion of a covered work in an aggregate does not cause this License to apply to the other parts of the aggregate.

7. Conveying Non-Source Forms.

You may convey a covered work in object code form under the terms of sections 4 and 5, provided that you also convey the machine-readable Corresponding Source under the terms of this License, in one of these ways:

- a. Convey the object code in, or embodied in, a physical product (including a physical distribution medium), accompanied by the Corresponding Source fixed on a durable physical medium customarily used for software interchange.
- b. Convey the object code in, or embodied in, a physical product (including a physical distribution medium), accompanied by a written offer, valid for at least three years and valid for as long as you offer spare parts or customer support for that product model, to give anyone who possesses the object code either (1) a copy of the Corresponding Source for all the software in the product that is covered by this License, on a durable physical medium customarily used for software interchange, for a price no more than your reasonable cost of physically performing this conveying of source, or (2) access to copy the Corresponding Source from a network server at no charge.
- c. Convey individual copies of the object code with a copy of the written offer to provide the Corresponding Source. This alternative is allowed only occasionally and noncommercially, and only if you received the object code with such an offer, in accord with subsection 6b.
- d. Convey the object code by offering access from a designated place (gratis or for a charge), and offer equivalent access to the Corresponding Source in the same way through the same place at no further charge. You need not require recipients to copy the Corresponding Source along with the object code. If the place to copy the object code is a network server, the Corresponding Source may be on a different server (operated by you or a third party) that supports equivalent copying facilities, provided you maintain clear directions next to the object code saying where to find the Corresponding Source. Regardless of what server hosts the Corresponding Source, you remain obligated to ensure that it is available for as long as needed to satisfy these requirements.

- e. Convey the object code using peer-to-peer transmission, provided you inform other peers where the object code and Corresponding Source of the work are being offered to the general public at no charge under subsection 6d.

A separable portion of the object code, whose source code is excluded from the Corresponding Source as a System Library, need not be included in conveying the object code work.

A “User Product” is either (1) a “consumer product”, which means any tangible personal property which is normally used for personal, family, or household purposes, or (2) anything designed or sold for incorporation into a dwelling. In determining whether a product is a consumer product, doubtful cases shall be resolved in favor of coverage. For a particular product received by a particular user, “normally used” refers to a typical or common use of that class of product, regardless of the status of the particular user or of the way in which the particular user actually uses, or expects or is expected to use, the product. A product is a consumer product regardless of whether the product has substantial commercial, industrial or non-consumer uses, unless such uses represent the only significant mode of use of the product.

“Installation Information” for a User Product means any methods, procedures, authorization keys, or other information required to install and execute modified versions of a covered work in that User Product from a modified version of its Corresponding Source. The information must suffice to ensure that the continued functioning of the modified object code is in no case prevented or interfered with solely because modification has been made.

If you convey an object code work under this section in, or with, or specifically for use in, a User Product, and the conveying occurs as part of a transaction in which the right of possession and use of the User Product is transferred to the recipient in perpetuity or for a fixed term (regardless of how the transaction is characterized), the Corresponding Source conveyed under this section must be accompanied by the Installation Information. But this requirement does not apply if neither you nor any third party retains the ability to install modified object code on the User Product (for example, the work has been installed in ROM).

The requirement to provide Installation Information does not include a requirement to continue to provide support service, warranty, or updates for a work that has been modified or installed by the recipient, or for the User Product in which it has been modified or installed. Access to a network may be denied when the modification itself materially and adversely affects the operation of the network or violates the rules and protocols for communication across the network.

Corresponding Source conveyed, and Installation Information provided, in accord with this section must be in a format that is publicly documented (and with an implementation available to the public in source code form), and must require no special password or key for unpacking, reading or copying.

8. Additional Terms.

“Additional permissions” are terms that supplement the terms of this License by making exceptions from one or more of its conditions. Additional permissions that are applicable to the entire Program shall be treated as though they were included in this License, to the extent that they are valid under applicable law. If additional permissions apply only to part of the Program, that part may be used separately under those permissions, but the entire Program remains governed by this License without regard to the additional permissions.

When you convey a copy of a covered work, you may at your option remove any additional permissions from that copy, or from any part of it. (Additional permissions may be written to require their own removal in certain cases when you modify the work.) You may place additional permissions on material, added by you to a covered work, for which you have or can give appropriate copyright permission. Notwithstanding any other provision of this License, for material you add to a covered work, you may (if authorized by the copyright holders of that material) supplement the terms of this License with terms:

- a. Disclaiming warranty or limiting liability differently from the terms of sections 15 and 16 of this License; or
- b. Requiring preservation of specified reasonable legal notices or author attributions in that material or in the Appropriate Legal Notices displayed by works containing it; or
- c. Prohibiting misrepresentation of the origin of that material, or requiring that modified versions of such material be marked in reasonable ways as different from the original version; or

- d. Limiting the use for publicity purposes of names of licensors or authors of the material; or
- e. Declining to grant rights under trademark law for use of some trade names, trademarks, or service marks; or
- f. Requiring indemnification of licensors and authors of that material by anyone who conveys the material (or modified versions of it) with contractual assumptions of liability to the recipient, for any liability that these contractual assumptions directly impose on those licensors and authors. All other non-permissive additional terms are considered "further restrictions" within the meaning of section 10. If the Program as you received it, or any part of it, contains a notice stating that it is governed by this License along with a term that is a further restriction, you may remove that term. If a license document contains a further restriction but permits relicensing or conveying under this License, you may add to a covered work material governed by the terms of that license document, provided that the further restriction does not survive such relicensing or conveying. If you add terms to a covered work in accord with this section, you must place, in the relevant source files, a statement of the additional terms that apply to those files, or a notice indicating where to find the applicable terms. Additional terms, permissive or non-permissive, may be stated in the form of a separately written license, or stated as exceptions; the above requirements apply either way.

9. Termination.

You may not propagate or modify a covered work except as expressly provided under this License. Any attempt otherwise to propagate or modify it is void, and will automatically terminate your rights under this License (including any patent licenses granted under the third paragraph of section 11).

However, if you cease all violation of this License, then your license from a particular copyright holder is reinstated (a) provisionally, unless and until the copyright holder explicitly and finally terminates your license, and (b) permanently, if the copyright holder fails to notify you of the violation by some reasonable means prior to 60 days after the cessation.

Moreover, your license from a particular copyright holder is reinstated permanently if the copyright holder notifies you of the violation by some reasonable means, this is the first time you have received notice of violation of this License (for any work) from that copyright holder, and you cure the violation prior to 30 days after your receipt of the notice.

Termination of your rights under this section does not terminate the licenses of parties who have received copies or rights from you under this License. If your rights have been terminated and not permanently reinstated, you do not qualify to receive new licenses for the same material under section 10.

10. Acceptance Not Required for Having Copies.

You are not required to accept this License in order to receive or run a copy of the Program. Ancillary propagation of a covered work occurring solely as a consequence of using peer-to-peer transmission to receive a copy likewise does not require acceptance. However, nothing other than this License grants you permission to propagate or modify any covered work. These actions infringe copyright if you do not accept this License. Therefore, by modifying or propagating a covered work, you indicate your acceptance of this License to do so.

11. Automatic Licensing of Downstream Recipients.

Each time you convey a covered work, the recipient automatically receives a license from the original licensors, to run, modify and propagate that work, subject to this License. You are not responsible for enforcing compliance by third parties with this License.

An "entity transaction" is a transaction transferring control of an organization, or substantially all assets of one, or subdividing an organization, or merging organizations. If propagation of a covered work results from an entity transaction, each party to that transaction who receives a copy of the work also receives whatever licenses to the work the party's predecessor in interest had or could give under the previous paragraph, plus a right to possession of the Corresponding Source of the work from the predecessor in interest, if the predecessor has it or can get it with reasonable efforts.

You may not impose any further restrictions on the exercise of the rights granted or affirmed under this License. For example, you may not impose a license fee, royalty, or other charge for exercise of rights granted under this License, and you may not initiate litigation (including a cross-claim or counterclaim in

a lawsuit) alleging that any patent claim is infringed by making, using, selling, offering for sale, or importing the Program or any portion of it.

12. Patents.

A “contributor” is a copyright holder who authorizes use under this License of the Program or a work on which the Program is based. The work thus licensed is called the contributor’s “contributor version” .

A contributor’s “essential patent claims” are all patent claims owned or controlled by the contributor, whether already acquired or hereafter acquired, that would be infringed by some manner, permitted by this License, of making, using, or selling its contributor version, but do not include claims that would be infringed only as a consequence of further modification of the contributor version. For purposes of this definition, “control” includes the right to grant patent sublicenses in a manner consistent with the requirements of this License.

Each contributor grants you a non-exclusive, worldwide, royalty-free patent license under the contributor’s essential patent claims, to make, use, sell, offer for sale, import and otherwise run, modify and propagate the contents of its contributor version.

In the following three paragraphs, a “patent license” is any express agreement or commitment, however denominated, not to enforce a patent (such as an express permission to practice a patent or covenant not to sue for patent infringement). To “grant” such a patent license to a party means to make such an agreement or commitment not to enforce a patent against the party.

If you convey a covered work, knowingly relying on a patent license, and the Corresponding Source of the work is not available for anyone to copy, free of charge and under the terms of this License, through a publicly available network server or other readily accessible means, then you must either (1) cause the Corresponding Source to be so available, or (2) arrange to deprive yourself of the benefit of the patent license for this particular work, or (3) arrange, in a manner consistent with the requirements of this License, to extend the patent license to downstream recipients. “Knowingly relying” means you have actual knowledge that, but for the patent license, your conveying the covered work in a country, or your recipient’s use of the covered work in a country, would infringe one or more identifiable patents in that country that you have reason to believe are valid.

If, pursuant to or in connection with a single transaction or arrangement, you convey, or propagate by procuring conveyance of, a covered work, and grant a patent license to some of the parties receiving the covered work authorizing them to use, propagate, modify or convey a specific copy of the covered work, then the patent license you grant is automatically extended to all recipients of the covered work and works based on it.

A patent license is “discriminatory” if it does not include within the scope of its coverage, prohibits the exercise of, or is conditioned on the non-exercise of one or more of the rights that are specifically granted under this License. You may not convey a covered work if you are a party to an arrangement with a third party that is in the business of distributing software, under which you make payment to the third party based on the extent of your activity of conveying the work, and under which the third party grants, to any of the parties who would receive the covered work from you, a discriminatory patent license (a) in connection with copies of the covered work conveyed by you (or copies made from those copies), or (b) primarily for and in connection with specific products or compilations that contain the covered work, unless you entered into that arrangement, or that patent license was granted, prior to 28 March 2007.

Nothing in this License shall be construed as excluding or limiting any implied license or other defenses to infringement that may otherwise be available to you under applicable patent law.

13. No Surrender of Others' Freedom.

If conditions are imposed on you (whether by court order, agreement or otherwise) that contradict the conditions of this License, they do not excuse you from the conditions of this License. If you cannot convey a covered work so as to satisfy simultaneously your obligations under this License and any other pertinent obligations, then as a consequence you may not convey it at all. For example, if you agree to terms that obligate you to collect a royalty for further conveying from those to whom you convey the Program, the only way you could satisfy both those terms and this License would be to refrain entirely from conveying the Program.

14. Use with the GNU Affero General Public License.

Notwithstanding any other provision of this License, you have permission to link or combine any covered work with a work licensed under version 3 of the GNU Affero General Public License into a single combined work, and to convey the resulting work. The terms of this License will continue to apply to the part which is the covered work, but the special requirements of the GNU Affero General Public License, section 13, concerning interaction through a network will apply to the combination as such.

15. Revised Versions of this License.

The Free Software Foundation may publish revised and/or new versions of the GNU General Public License from time to time. Such new versions will be similar in spirit to the present version, but may differ in detail to address new problems or concerns.

Each version is given a distinguishing version number. If the Program specifies that a certain numbered version of the GNU General Public License "or any later version" applies to it, you have the option of following the terms and conditions either of that numbered version or of any later version published by the Free Software Foundation. If the Program does not specify a version number of the GNU General Public License, you may choose any version ever published by the Free Software Foundation.

If the Program specifies that a proxy can decide which future versions of the GNU General Public License can be used, that proxy's public statement of acceptance of a version permanently authorizes you to choose that version for the Program.

Later license versions may give you additional or different permissions. However, no additional obligations are imposed on any author or copyright holder as a result of your choosing to follow a later version.

16. Disclaimer of Warranty.

THERE IS NO WARRANTY FOR THE PROGRAM, TO THE EXTENT PERMITTED BY APPLICABLE LAW. EXCEPT WHEN OTHERWISE STATED IN WRITING THE COPYRIGHT HOLDERS AND/OR OTHER PARTIES PROVIDE THE PROGRAM "AS IS" WITHOUT WARRANTY OF ANY KIND, EITHER EXPRESSED OR IMPLIED, INCLUDING, BUT NOT LIMITED TO, THE IMPLIED WARRANTIES OF MERCHANTABILITY AND FITNESS FOR A PARTICULAR PURPOSE. THE ENTIRE RISK AS TO THE QUALITY AND PERFORMANCE OF THE PROGRAM IS WITH YOU. SHOULD THE PROGRAM PROVE DEFECTIVE, YOU ASSUME THE COST OF ALL NECESSARY SERVICING, REPAIR OR CORRECTION.

17. Limitation of Liability.

IN NO EVENT UNLESS REQUIRED BY APPLICABLE LAW OR AGREED TO IN WRITING WILL ANY COPYRIGHT HOLDER, OR ANY OTHER PARTY WHO MODIFIES AND/OR CONVEYS THE PROGRAM AS PERMITTED ABOVE, BE LIABLE TO YOU FOR DAMAGES, INCLUDING ANY GENERAL, SPECIAL, INCIDENTAL OR CONSEQUENTIAL DAMAGES ARISING OUT OF THE USE OR INABILITY TO USE THE PROGRAM (INCLUDING BUT NOT LIMITED TO LOSS OF DATA OR DATA BEING RENDERED INACCURATE OR LOSSES SUSTAINED BY YOU OR THIRD PARTIES OR A FAILURE OF THE PROGRAM TO OPERATE WITH ANY OTHER PROGRAMS), EVEN IF SUCH HOLDER OR OTHER PARTY HAS BEEN ADVISED OF THE POSSIBILITY OF SUCH DAMAGES.

18. Interpretation of Sections 16 and 17.

If the disclaimer of warranty and limitation of liability provided above cannot be given local legal effect according to their terms, reviewing courts shall apply local law that most closely approximates an absolute waiver of all civil liability in connection with the Program, unless a warranty or assumption of liability accompanies a copy of the Program in return for a fee.

END OF TERMS AND CONDITIONS

CE 聲明



此 QNAP NAS 符合 CE 規範等級 A。

FCC 聲明

FCC A 級聲明



本產品符合 FCC 規則第 15 部分。產品操作須遵守以下兩個條件：

1. 本產品不得造成有害干擾。
2. 本產品必須承受任何收到的干擾，包含可能造成額外操作的干擾。



注意

本產品已通過測試並符合 FCC 規則第 15 部分 A 級數位裝置之限制。此等限制旨在此裝置於商業環境中操作時，提供免於有害干擾之合理保護所設計。本產品產生、使用、並可能放射無線電頻率能量，若未依據指示安裝及使用，可能對無線電通訊造成有害干擾。在住宅區操作本產品可能會造成有害干擾。在這種情況下，使用者必須自行解決干擾現象。



重要

任何未經過威聯通科技股份有限公司同意而對此產品進行修改，可能會讓使用者根據 FCC 規範操作本設備的權力失效。

VCCI 聲明



この装置は、クラス A 情報技術装置です。この装置を家庭環境で使用すると電波妨害を引き起こすことがあります。この場合には使用者が適切な対策を講ずるよう要求されることがあります。

VCCI-A

經濟部標準檢驗局聲明



D33B77
RoHS

警告使用者：這是甲類的資訊產品，在居住的環境中使用時，可能會造成射頻干擾，在這種情況下，使用者會被要求採取某些適當的對策。

SJ/T 11364-2006



本产品符合中国 RoHS 标准。以下表格标示此产品中某有毒物质的含量符合中国 RoHS 标准规定的限量要求。

本产品上会附有“环境友好使用期限”的标签，此期限是估算这些物质“不会有泄漏或突变”的年限。本产品可能包含有较短的环境友好使用期限的可替换元件，像是电池或灯管，这些元件将会单独标示出来。

部件名称	有毒有害物质或元素					
	铅 (Pb)	汞 (Hg)	镉 (Cd)	六价铬 (CR(VI))	多溴联苯 (PBB)	多溴二苯醚 (PBDE)
壳体	0	0	0	0	0	0
显示	0	0	0	0	0	0
印刷电路板	0	0	0	0	0	0
金属螺帽	0	0	0	0	0	0
电缆组装	0	0	0	0	0	0
风扇组装	0	0	0	0	0	0
电力供应组装	0	0	0	0	0	0
电池	0	0	0	0	0	0

O: 表示该有毒有害物质在该部件所有物质材料中的含量均在 SJ/T11363-2006 标准规定的限量要求以下。
X: 表示该有毒有害物质至少在该部件的某一均质材料中的含量超出 SJ/T11363-2006 标准规定的限量要求。